

PowerBoss[®]

Instruction Manual

Admiral 48D (7580.45)

Introduction

Preface

Dear Customer,
We are certain that the excellent qualities of the vehicle will justify the faith you have shown in us through your purchase.

Your safety, and that of others, basically lies in your ability to control and operate the vehicle. Before using the vehicle for the first time, read this translation of the original manual thoroughly, act according to the information contained and keep it in a safe place for future reference or subsequent owners. Please read the Chapter "Safety Information" prior to starting the vehicle to ensure it is operated and used safely.

The operating manual contains all the most important information regarding operation, maintenance and service. Throughout this manual, texts which concern safety are indicated by the corresponding danger pictogram. Should you have any questions in respect of the vehicle or operating instruction manual, your authorized PowerBoss dealer is available to provide help at any time.

We explicitly point out that no legal claims may be asserted based on the information contained in this manual. Please pay attention that only original spare parts are used for any necessary maintenance and repair work. Only original spare parts can guarantee long, reliable equipment operation. We reserve the right to make technical improvements.

Valid from: January 2012

PowerBoss Inc.
175 Anderson Street
NC 28315 U.S.A.
Telephone: (910) 944-2105
Fax: (910) 944-740

Intended use

The Admiral 48D is a scrubber-drier vehicle conceived for wet cleaning hard floors indoors. Any use beyond this is regarded as improper use. The manufacturer is not considered liable for any damage resulting from improper use; the user is solely responsible for all the risks.



The scrubber-drier has not been approved for use on public paths and roads.

Intended use also includes maintaining and observing the operating, maintenance and repair conditions prescribed by the manufacturer. The scrubber-drier may only be operated, serviced and repaired by personnel who are familiar with the work involved and are aware of the risks.

The applicable accident prevention laws must be observed and any generally accepted health and safety directives must be maintained. Based on the conception, design and construction of the vehicle introduced onto the market by us, the vehicle complies with the applicable basic

Introduction

safety and health requirements stipulated in the EC Directive (refer to the Declaration of Conformity). This declaration is no longer considered valid in the event of modifications to the vehicle not authorized by us. The manufacturer is not deemed liable for any damage resulting from unauthorized modifications to the vehicle.

Notes on warranty

The terms defined in the purchase agreement apply. Claims for compensation related to damage are excluded from the terms of warranty when the damage is the result of failure to observe regulations concerning service and maintenance. Maintenance work must be performed by authorized PowerBoss service centers and confirmed in the "Maintenance Report" which serves as a warranty logbook. The following are excluded from the terms of warranty: wear and tear through overuse, defective fuses, improper handling and use or unauthorized modifications. Claims under the terms of warranty are annulled when damage occurs to the vehicle resulting from the use of parts or accessories not explicitly approved by us or from failure to observe maintenance regulations.

Acceptance of the machine

Inspect the vehicle immediately on delivery for signs of transport damage. It will be replaced when the damage is immediately confirmed by the haulage contractor and the damage report is sent to our authorized sales partner together with the consignment note.

Contents

Introduction	2	3	Operation	27	3.3.5	Switching the vehicle off. . . .	61
Preface	2	3.1	Method of operation	27	3.3.6	Loading and	
Intended use.	2	3.1.1	Pre-sweep/vacuum unit	27		transporting the vehicle	61
Notes on warranty	3	3.1.2	Scrubbing unit	28	3.4	After finishing work.	62
Acceptance of the machine . . .	3	3.1.3	Squeegee.	29	3.5	Function faults	63
		3.1.4	Suction turbines (suction). . . .	29	3.5.1	Error code table	63
1	Safety Information	3.1.5	Fresh water tank.	30	3.5.2	Other function faults	65
1.1	Safety and warning symbols . .	3.1.6	Recovery tank	31			
1.2	General information	3.1.7	Traction drive	32	4	Technical Data	66
1.3	Operating information.	3.1.8	Brakes	32	5	Maintenance	
1.4	Maintenance information . . .	3.1.9	Batteries and charger.	33		and Service	75
1.5	Particular risks	3.1.10	Options.	35	5.1	PowerBoss	
1.5.1	Electronics	3.2	Operating and			system maintenance	75
1.5.2	Batteries		indicator elements	39	5.2	Maintenance report	76
1.6	Environmental protection . . .	3.2.1	Operating elements		5.3	Maintenance schedule	77
1.7	Labels on the vehicle		in the driver's cab.	39	5.3.1	PowerBoss system	
		3.2.2	Left-hand			maintenance, customer	77
2	Starting Up		operating panel.	42	5.3.2	PowerBoss	
2.1	Instruction.	3.2.3	Right-hand			system maintenance I	80
2.2	Initial battery charge.		operating panel.	48	5.3.3	PowerBoss	
2.3	Prior to starting up	3.2.4	Operating elements			system maintenance II	84
	for the first time.		on the vehicle.	52	5.3.4	PowerBoss system	
2.3.1	Installing brushes and pads . .	3.3	Operation	56		maintenance III/S	
2.3.2	Installing and adjusting	3.3.1	Switching the vehicle on. . . .	56		(safety check).	85
	the squeegee	3.3.2	Accelerating	57			
2.3.3	Adjusting the driver's seat . . .	3.3.3	Stopping and parking	57			
2.4	Before starting up daily.	3.3.4	Cleaning.	57			

Contents



5.4	Battery system	86	5.6.4	Cleaning the air intake filter	98	5.11	Electrical installation	112
5.4.1	Charging batteries	87	5.6.5	Cleaning the openings to the fresh water tank	98	5.11.1	Red control lamps	112
5.4.2	Servicing the driving batteries	88	5.7	Scrubbing unit	99	5.11.2	Error codes	112
5.4.3	Disassembling the battery	88	5.7.1	Changing the brushes	99	5.11.3	Fuses	112
5.4.4	Installing the battery	90	5.7.2	Installing new rubber deflector strips.	100	5.11.4	Drive control relay	112
5.4.5	Disposing of batteries.	90	5.8	Squeegee	101	5.12	Cleaning the vehicle	113
5.4.6	Deep discharge signal transducer (BMS).	91	5.8.1	Cleaning the squeegee	101	5.13	Transport and towing	114
5.5	Fresh water tank.	92	5.8.2	Disassembling the squeegee	101			
5.5.1	Filling the fresh water tank	93	5.8.3	Installing the squeegee	102			
5.5.2	Emptying the fresh water tank	94	5.8.4	Changing the sealing strips	102			
5.5.3	Cleaning the draining hose cap.	94	5.8.5	Adjusting the support rollers.	103			
5.5.4	Cleaning the fresh water filter	94	5.9	Pre-sweep/Vacuum unit	104			
5.6	Recovery tank	95	5.9.1	Emptying the dirt hopper	104			
5.6.1	Emptying the recovery tank	96	5.9.2	Dust vacuum	105			
5.6.2	Cleaning the recovery tank	96	5.9.3	Side brushes	106			
5.6.3	Cleaning the draining hose cap.	97	5.9.4	Cylindrical brush.	107			
			5.10	Wheels	111			
			5.10.1	Changing the rear wheels	111			
			5.10.2	Changing the front wheel	111			
							PowerBoss Warranty	116

Safety Information

1 Safety Information

1.1 Safety and warning symbols

All texts related to personal safety, safety of the vehicle and environmental protection are assigned the following symbols throughout the operating manual:

Symbol	Risks to ...	Definition
Safety information 	persons or property	Safety information to prevent the development of hazardous situations resulting from ignoring or failing to follow instructions or prescribed work procedures.
Note 	the machine	Important information on handling the equipment in order to maintain its functionality.
Ecological hazard 	the environment	Ecological hazard through the use of substances which represent a potential hazard to health and the environment.

Safety Information

1.2 General information

- The scrubber-drier fulfills all the applicable safety and health requirements stipulated in the EC directives with regard to its planning, constructional design and final construction as introduced by us onto the market. In the case of modifications to the vehicle not approved by us, the EC Declaration of Conformity enclosed in this operating manual loses its validity.
- In addition to the information provided in this operating manual, all the legally applicable health and safety provisions must be observed.
- Before starting up the vehicle for the first time, read the operating manual supplied with it thoroughly as well as any separate manuals provided with additional or attachment devices and observe all the information during work.
- The vehicle may only be operated, maintained and repaired by persons trained by PowerBoss or authorized to do so by PowerBoss.
- Particular attention should be paid to the information regarding safety. Technical expertise is the key to preventing errors when operating the equipment and ensuring trouble-free operation.
- The operating manual must always be kept at the operating location of the vehicle and, as a result, should be kept in a safe place on the vehicle.
- If the equipment is sold or rented out, these documents should be transferred to the new owner/operator. The transfer should be confirmed!
- The warning labels attached to the equipment provide important information concerning safe operation. Labels which are illegible or missing must be replaced.
- Original spare parts must be used to ensure safety.
- If you want to shut the vehicle down, render it inoperable. It must not represent a source of danger for children.
- The positional information "left" and "right" always related to looking to the front when in the vehicle.

Safety Information

1.3 Operating information

- Before starting the vehicle up for the first time, the battery to be used must be fully charged, properly, by implementing the initial battery charge routine. Please pay attention to the operating manual provided with the charging unit as well as the manual from the battery manufacturer. PowerBoss assumes no liability for damage to the battery caused by a fault when the battery is charged for the first time.
- Before starting the vehicle up, always check it is in a proper condition and that it is safe to drive and operate. Clear up any faults and defects immediately! Never operate the vehicle without functional safety equipment.
- Warning: Do not use the vehicle without a protective roof structure (refer to "Accessories", "Cab safety roof") in areas in which the driver is at risk of being hit by falling objects (e.g. warehouses). Contact the trade association responsible for you as to whether obligations exist in this respect.
- The scrubber-drier must be

subjected to an inspection in respect of its operationally safe condition at least once a year by an authorized technical expert. The results of the inspection must be documented in writing and kept safe at least until the next inspection.

- Floor cleaning machines may only be operated by suitable personnel who have been trained to operate the equipment, have proven their capability to operate the vehicle to the contractor or person appointed by him and have been explicitly charged by him to operate the vehicle.
- Before starting work, operating personnel must be fully familiar with all adjustment, operating and control elements as well as their respective function! It is too late to do this when the vehicle is actually in operation!
- The warning labels attached to the scrubber-drier provide important information concerning safe operation.
- Wet floors are a potential risk for slipping! Ensure to provide the corresponding information and warning signs.

- If the floor is excessively wet, check the vehicle for leaks and that the sealing strips are in a good condition. If the sealing strips are damaged, change them immediately.
- Only use cleaning agents suitable for the vendor (non-foaming) and observe all the use, disposal and warning information provided by the cleaning agent manufacturer.
- It is forbidden to use the vehicle in potentially explosive atmospheres.
- The vehicle is not suitable for clearing up health-hazardous, inflammable or explosive fluids or dusts and substances with similar properties.
- Ride-on equipment may only be set into motion from the seat (seat contact switch).
- The seat contact switch must never be bypassed or the function immobilized in any way (e.g. by placing a heavy load on the seat).
- It is forbidden to transport people on the vehicle!
- Always wear heavy duty, non-slip footwear when working with the vehicle.

Safety Information

- Start driving immediately after switching on the brush head drive otherwise the brush could produce impressions on the floor.
- The machine may only be driven on and the equipment used on those surfaces which have been approved by the contractor or person appointed by him.
- The manner of driving must be adapted to the local conditions (floor characteristics, presence of persons in the vicinity, obstacles, etc.).
- When using the vehicle, it is essential to pay attention to third parties, especially children.
- Never leave the vehicle unattended while motors are still running and it has not been locked against unintended movement.
- To prevent authorized use of the vehicle, lock the drive by removing the key from the key switch.
- When transporting the vehicle, the motors must be shutdown.
- Only open empty recovery tanks.
- The scrubber-drier may only be driven on hard-surfaced, sufficiently non-slip ground (e.g. asphalt, concrete) which is free of oil, water, snow etc.
- The vehicle may only be driven on gradients to a maximum of 6% for a maximum of three minutes when in work mode. Do not drive the vehicle on slopes with a gradient steeper than the limit gradient indicated on the vehicle.



The climbing capacities stipulated in this manual can and may only be achieved with the battery specified in the Section „Technical Data“.



When cleaning on slopes, the traction may be restricted.

- When driving to its place of deployment (transport mode), the vehicle may only be driven on gradients to a maximum of 15% for a maximum of 15 seconds. When driving the vehicle in transport mode, the ground must be clean and dry, i.e. free of dirt, oil, snow, water etc., particularly when driving on gradients.

Safety Information

1.4 Maintenance information

Properly completed vehicle maintenance is an important measure in preventing accidents.

- The maintenance work and maintenance intervals prescribed in the operating manual must be adhered to.
- Operating personnel must complete the necessary daily and weekly maintenance work. All other maintenance work must be completed at your nearest authorized PowerBoss service center.
- Before starting any cleaning and maintenance work or replacing parts, switch off the motors, remove the key from the key switch and pull out the battery plug. This is particularly important in respect of work on the electrical system!
- Before working on the brushes, switch off the scrubbing unit, set the key switch to position 0 and remove the key.
- The scrubbing unit may only be disassembled and installed by service personnel.
- Suitable tools must be used for

cleaning and maintenance work.

- Spare parts must comply with the minimum technical requirements stipulated by the manufacturer! This is ensured by the use of original spare parts.
- When working in the area of the raised seat console, it must be pivoted up fully to prevent it accidentally closing or suddenly slamming shut.
- It is not permitted to clean the vehicle with a pressure washer or steam blaster.
- Clean the recovery tank regularly to protect it from the accumulation of dirt, viruses, bacteria, etc.
- It is not permitted to use aggressive and corrosive cleaning agents.
- Allow the vehicle to dry after being cleaned, e.g. over the weekend.
- The vehicle must be checked by a recognized technical expert in respect of operational safety at reasonable intervals (we recommend at least one a year), particularly with regard to protective equipment and locks and following modifications or repair.
- Only start the vehicle up when all the

safety equipment has been installed, is functional and brought to its protecting position.

- The vehicle has been set up for operation using low-maintenance batteries. If other battery types are to be used, the vehicle must be adjusted for them by an authorized PowerBoss service center.
- Observe the information in the operating manual provided by the battery manufacturer. These must be available to operating and maintenance personnel at all times.
- Batteries may only be handled and changed by properly skilled maintenance personnel.
- When installing the battery, use appropriate lifting gear.
- Only use batteries and chargers recommended by us. The full terms of warranty can only be accepted when these units are used.
- Pay attention that the insulation on the charger is not initially damaged and not damaged during the charging process. The cable must not rub against anything. Do not use the charger if the insulation is damaged.

Safety Information

- Always wear appropriate protective clothing when handling the battery (e.g. protective gloves, finger stalls, protective goggles).
- The seat console must be pivoted open during the battery charging process to prevent the development of explosive oxyhydrogen!
- Never leave the batteries in a discharged state but recharge them as soon as possible.
- Only refill distilled water.
- When the cells are in good condition, never refill battery acid.
- Spilled battery acid must never enter the sewage system in its initial form, it must be neutralized beforehand.
- Pay attention to legal requirements and local directives.
- For further safety information, see supplementary sheet 88-60-2554 "Notes on driving batteries".

Safety Information

1.5 Particular risks

- The following applies when locating and clearing faults: Switch the vehicle off, remove the key from the key switch and disconnect the battery plug!
- In the case of faults involving the traction drive, stop the vehicle immediately and remove the key from the key switch!

1.5.1 Electronics

- Always disconnect the battery plug before starting any work on the electrical installations.
- Only use original fuses with the prescribed amperage.
- In the case of defects in the electrical installation, switch the vehicle off immediately and clear the fault.
- Work on the electrical equipment may only be carried out by electricians who have received the necessary training and in accordance with the electrical engineering regulations.
- The vehicle's electrical equipment must be inspected/checked at regular intervals. Defects, such as loose connections and cable

damage, must be rectified immediately.

1.5.2 Batteries

- Due to a change in the center of gravity, only approved batteries may be installed at the intended position.
- To prevent creeping currents, always keep the batteries clean and dry and protect from contamination, e.g. from metal dust.
- Never lay any metallic objects or tools on batteries. Risk of short circuit and deflagration!
- Ensure sufficient ventilation in the charging area when charging the batteries. Otherwise there is a risk of explosion!
- The seat console must be pivoted open during the battery charging process to prevent the development of explosive oxyhydrogen!
- Only use recommended chargers! Pay attention that the insulation is not initially damaged and not damaged during the charging process. The cable must not rub against anything. Do not use the charger if the insulation is damaged.

- Ensure there are no naked flames nearby when handling batteries, particularly when checking the acidity. Risk of explosion!
- Do not inhale battery gases.
- Battery acid is very corrosive; keep away from children.
- Wear protective goggles when controlling the acid level.
- In the event of acid splashing in the eyes, rinse them with water for approx. 15 minutes and seek medical attention immediately.
- Also pay attention to the information in Section 1.4.

Safety Information

1.6 Environmental protection

- A certain factual expertise is required in order to use substances which could represent a risk to health and the environment.
- Always observe legal regulations and local directives when disposing of cleaning agents.

Disposing of batteries

Used batteries with the recycling symbol contain reusable commodities. The heavy metals contained represent a major risk both to people's health and to the environment. Never open or damage batteries. Never touch, inhale or swallow the content of batteries. Health hazard! Do not allow batteries to get into the environment. Risk of contaminating the soil and water! In accordance with symbol with the crossed out garbage bin, these batteries must not be disposed of in domestic waste. Return and recycling of old batteries must be agreed on with the authorized PowerBoss dealer in accordance with national requirements.

Disposing of the vehicle

- Render the vehicle inoperable. It must not represent a source of danger for children.
- Dispose of the vehicle in accordance with local regulations. For further information on handling and recycling, please contact the authorized PowerBoss dealer where you purchased the vehicle.

Safety Information

1.7 Labels on the vehicle

The following safety and warning labels are attached to the vehicle where easily legible.



Missing or illegible labels must be replaced immediately.

Company logo (Fig. 1/1) (Fig. 2/1)

PowerBoss®

Rating plate (Fig. 1/2)

The rating plate is in the driver's cab, at the bottom on the flap of the left-hand electrical compartment.

PowerBoss® CE	
Member of the Hako Group	
Power Boss Inc., 175 Anderson Street, Aberdeen, NC 28315 USA	
Made in Germany	
Model	<input type="text"/>
Serial No.	<input type="text"/>
<input type="text"/>	<input type="text"/>
<input type="text"/>	<input type="text"/>
<input type="text"/>	Total weight kg/ lb: <input type="text"/>

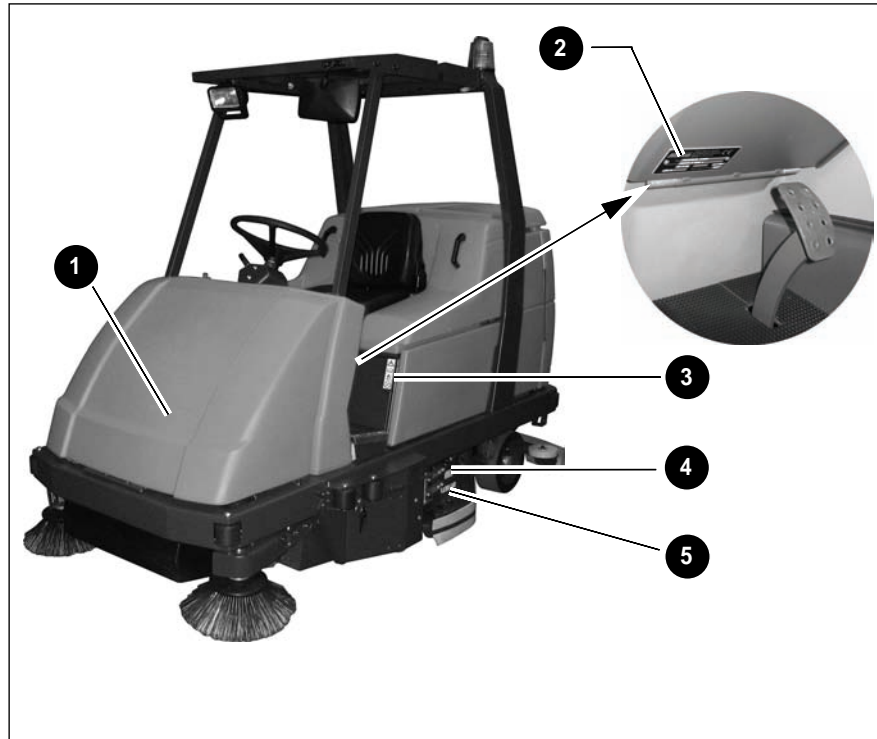
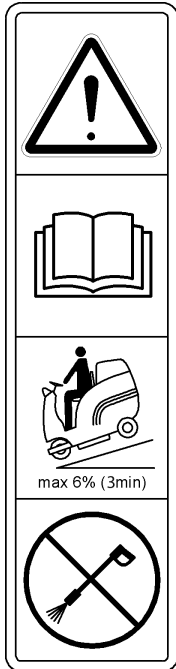

Fig. 1

Safety Information

Read the operating manual, gradient driving limits and never clean with a high-pressure washer (Fig. 1/3)



No standing on the deflectors
(Fig. 1/4)



Working width (Fig. 1/5)

The working width of the machine is specified in millimeters and in inches on the deflectors to the left and right: The vehicle has a working width of 1230 mm or 49 in.

1230/49

Safety Information

Drive direction selector:

Forwards or reverse (Fig. 2/6)

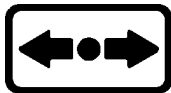

Release parking brake

(Fig. 2/7)



Apply parking brake

(Fig. 2/8)



Maximum water temperature for

water to be filled

(Fig. 2/9)

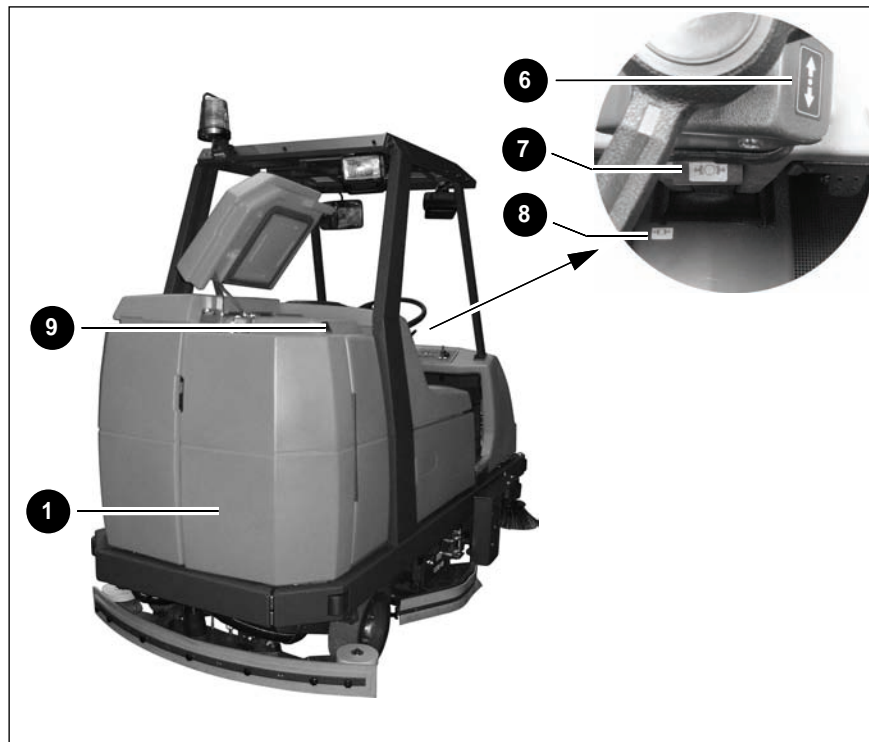
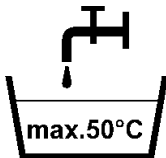

Fig. 2

Safety Information

Fresh water drainage

(Fig. 3/10)

The fresh water is drained via the hose which hangs to the left of this label.

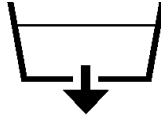

Waste water drainage

(Fig. 3/11)

The waste water is drained via the hose which hangs to the right of this label.

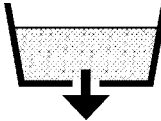

No waste water drainage

(Fig. 3/12)

The flap serves exclusively for cleaning and maintenance of the recovery tank.

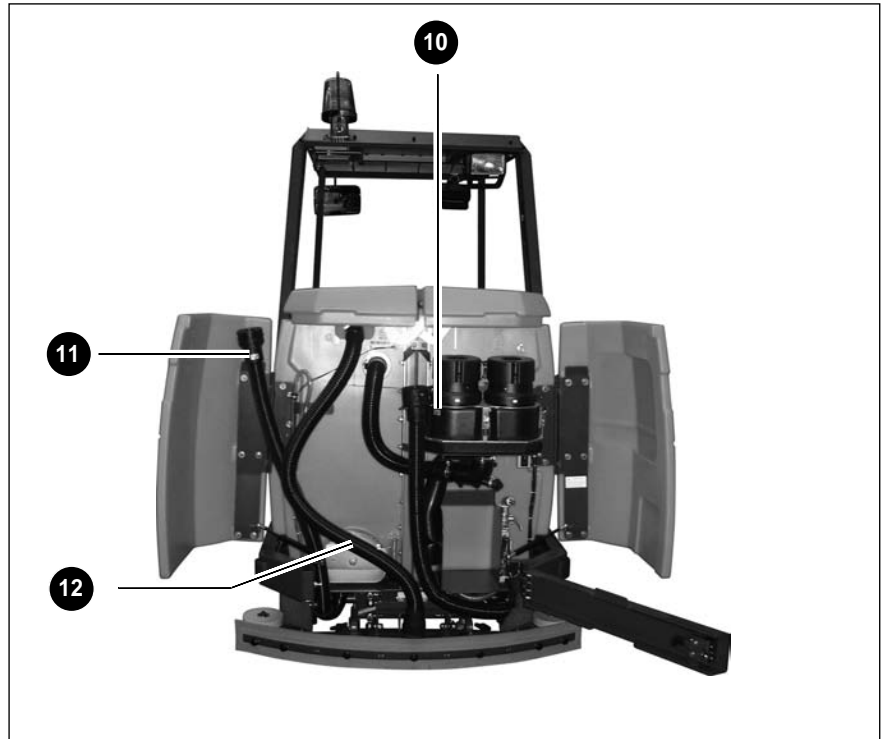

Fig. 3

Starting Up

2 Starting Up



Pay attention to persons in the vicinity of the vehicle when completing any work.

2.1 Instruction

Operators must receive instruction before the vehicle is put into service. Only technicians from your local authorized PowerBoss dealer are allowed to provide initial instruction on the vehicle. The manufacturing plant will notify the dealer immediately after delivering the vehicle and the dealer will contact you to arrange a date.

2.2 Initial battery charge

An initial battery charge must be performed on the batteries in order for them to provide an optimum performance and service life. A battery charger is available which is specially adapted to the batteries.

The seat console must be tipped up during the charging process. To do this, take hold of the seat console at the handle and pivot it forwards to open it.



The seat console must be pivoted open during the battery charging process to prevent the development of explosive oxyhydrogen!



Only use the original charger! Pay attention that the insulation is not initially damaged and not damaged during the charging process. The cable must not rub against anything. Do not use the charger if the insulation is damaged.



Do not inhale battery gases.



Only use batteries and chargers recommended by us. The full terms of warranty can only be accepted when these units are used.



Before starting the vehicle up for the first time, the batteries to be used must be fully charged, properly, by implementing the initial battery charge routine. PowerBoss assumes no liability for damage to the battery caused by a fault when the battery is charged for the first time.

Please pay attention to the operating manual provided with the charging unit as well as the manual from the battery manufacturer. Powering up the batteries is described in such detail in the manufacturer's documents, further information on the subject is considered unnecessary for this manual.

Starting Up

2.3 Prior to starting up for the first time

The following work must be completed before starting the vehicle up for the first time:

2.3.1 Installing brushes and pads

The machine must have three brushes or three pads fitted.



Before starting to use the vehicle for the first time, ensure that appropriate brushes or pads have been installed.



The brush head has to be in lifted position when changing the brushes.



Switch off the scrubbing unit, set the key switch to position 0 and remove the key.

Selecting brushes

The scrubber-drier must be equipped with the brushes and pads from the accessories program according to the degree of soiling and characteristics of the floor.



Refer to Section 4 for the brushes available.

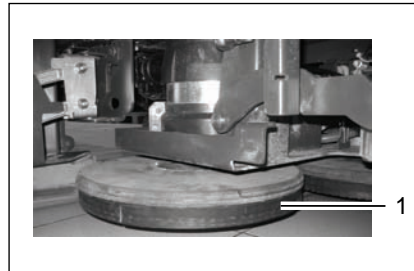

Fig. 4

At the factory, a water retaining ring (Fig. 4/1) is fitted to the brushes which reduces water consumption considerably during scrubbing.

Opening and closing the deflector

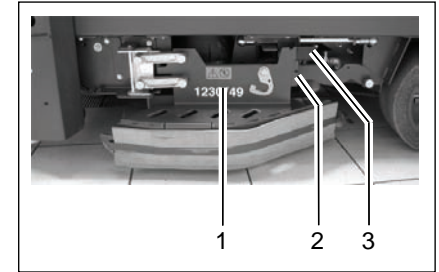

Fig. 5

- 1 Deflector
- 2 Deflector lock
- 3 Grip

Open the deflector (Fig. 5/1) before assembling or disassembling brushes and pads:

1. Take hold of the deflector (Fig. 5/1) by the grip (Fig. 5/3).
2. Raise the deflector (Fig. 5/1) and pivot outwards to the front.
3. Lower the deflector (Fig. 5/1) (service position).

The deflector is closed in the opposite sequence.

Starting Up

Assembly sequence

Assemble the middle brush or pad first and then mount the outer brushes/pads.

Disassembly sequence

The outer left brush or pad must be disassembled before the middle brush or pad can be disassembled.



Disassemble the middle brush or pad preferably from the left-hand side of the vehicle because the guiding aid for the assembly tools is located here.

Assembly tool

To simplify assembly and disassembly of the middle brush or pad in particular, an assembly tool (Fig. 6/4) is provided which is kept in a corresponding holder (Fig. 6/3) under the seat console which can be opened out.

Both sides of the plate (Fig. 6/1) of the assembly tool (Fig. 6/4) can be used:

- To assemble brushes, the flat side of the plate (Fig. 6/1) (without centering device (Fig. 6/6)) must point upwards.
- To assemble pads, the side of the plate (Fig. 6/1) with the centering device (Fig. 6/6) must point upwards.



There are pins (Fig. 6/2) on both sides of the plate (Fig. 6/1) which serve to center the brush or pad on the assembly tool.

Turn the plate:

1. Remove the screw (Fig. 6/5).
2. Remove the plate (Fig. 6/1) from the dowel (Fig. 6/7).
3. Turn the plate (Fig. 6/1) over.
4. Fit the plate (Fig. 6/1) upside down on the dowel (Fig. 6/7).
5. Insert and tighten the screw (Fig. 6/5).



The assembly tool (Fig. 6/4) can be used to assemble and disassemble all the brushes or pads.

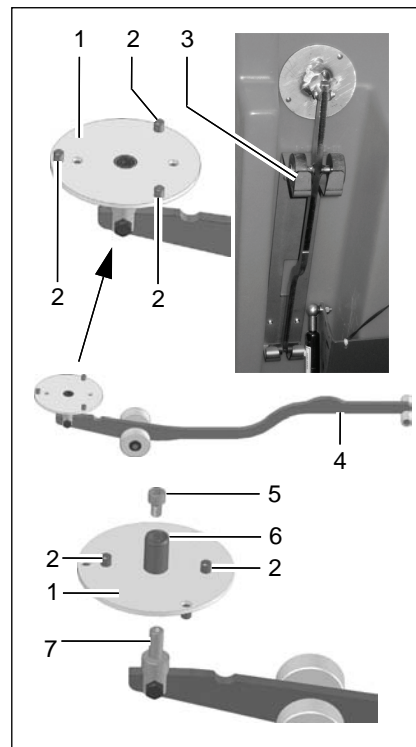

Fig. 6

Starting Up

Assembling the middle brush or middle pad

1. Open the deflector (Fig. 5/1), refer to paragraph "Opening and closing the deflector".
2. If necessary, remove the brushes or pads already installed, refer to paragraph "Disassembling the outer brushes / pads" and paragraph "Disassembling the middle brush or middle pad".
3. Position the middle brush (Fig. 7/2) or middle pad (Fig. 7/5) as illustrated in Fig. 7 on the assembly tool (Fig. 7/1).



The correct side of the plate of the assembly tool must point upwards, refer to paragraph "Assembly tool".

4. Take hold of the assembly tool (Fig. 7/1) at the narrow end and slide the brush (Fig. 7/2) or pad (Fig. 7/5) under the middle brush catch (Fig. 7/4).

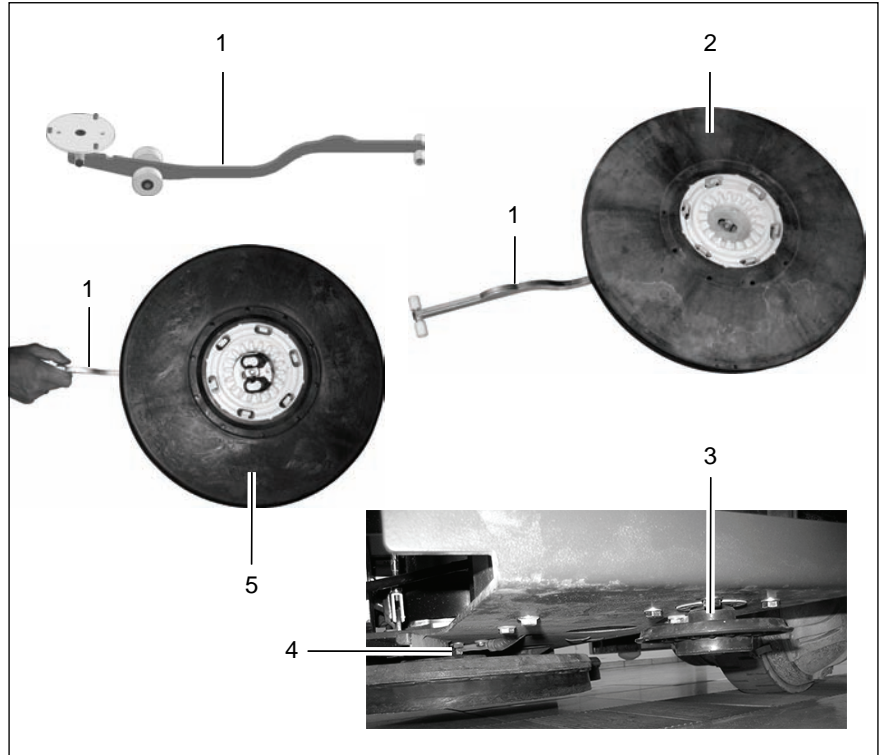

Fig. 7

Starting Up

- Force the narrow end of the assembly tool (Fig. 7/1) downwards. As a result of the levering effect, the brush (Fig. 7/2) or pad (Fig. 7/5) is pressed into the brush catch and audibly latches in place.
- In order to control whether all the hooks are in place, turn the brush or pad installed once.
- Continue by assembling the outer brushes, refer to paragraph "Assembling the outer brushes / pads".
- Close the deflector, refer to paragraph "Opening and closing the deflector". The deflector (Fig. 5/1) is now in its working position.

Assembling the outer brushes / pads

- Open the deflector (Fig. 5/1), refer to paragraph "Opening and closing the deflector".
- Slide the brush (Fig. 7/2) or pad (Fig. 7/5) under the brush head in accordance with Fig. 8.
- Raise the brush (Fig. 7/2) or pad (Fig. 7/5) and turn it slightly until the toothing meshes.
- Pull the brush (Fig. 7/2) or pad

(Fig. 7/5) up until all six hooks latch in the catches.

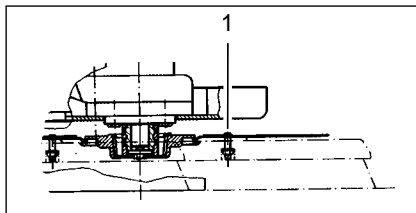

Fig. 8

- In order to control whether all the hooks are in place, turn the brush or pad installed once.
- Close the deflector, refer to paragraph "Opening and closing the deflector". The deflector (Fig. 5/1) is now in its working position.



You can also use the assembly tool as an aid to complete steps 2 to 4, refer to the corresponding steps 3 to 5 in paragraph "Assembling the middle brush or middle pad". When completing Step 5, pay attention that you must simultaneously use your free hand to push down on the

brush head! Exerting counterpressure is the only way to ensure that the brush or pad engages properly!

Disassembling the outer brushes / pads

- Open the deflector (Fig. 5/1), refer to paragraph "Opening and closing the deflector".
- Pull the brush (Fig. 7/2) or pad (Fig. 7/5) from the brush head. Or:
- Slide the narrow side of the assembly tool between the brush/pad and brush head and press the wide end of the assembly tool downwards. As a result of the levering effect, the brushes / pads are released from the brush head (Fig. 7/3).

Starting Up

Disassembling the middle brush or middle pad



To simplify disassembling the middle brush, a guiding aid is provided on the left-hand side.

1. Open the left-hand deflector, refer to paragraph "Opening and closing the deflector".
2. Disassemble the outer left brush or pad, refer to paragraph "Disassembling the outer brushes / pads".
3. Insert the narrow side of the assembly tool (Fig. 9/1) in the guiding aid (Fig. 9/2).
4. Slide the assembly tool (Fig. 9/1) as far as possible to the rear.
5. Force the broad end of the assembly tool with the plate (Fig. 6/1) downwards. As a result of the levering effect, the brush or pad (Fig. 9/3) is released from the brush head.
6. Draw the assembly tool (Fig. 9/1) back and remove from the guiding aid (Fig. 9/2).

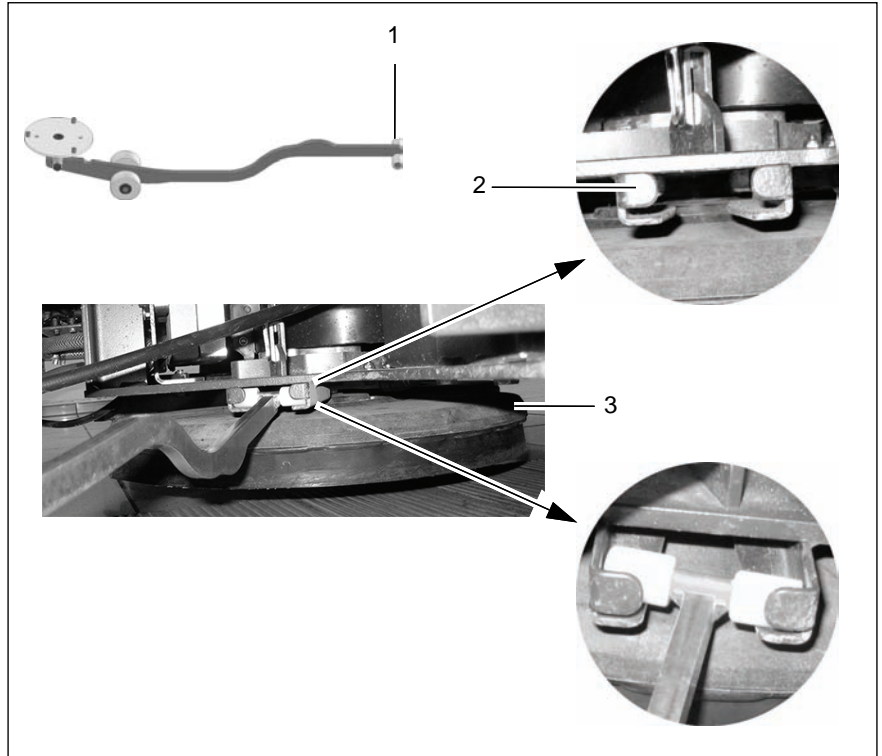

Fig. 9

Starting Up

2.3.2 Installing and adjusting the squeegee

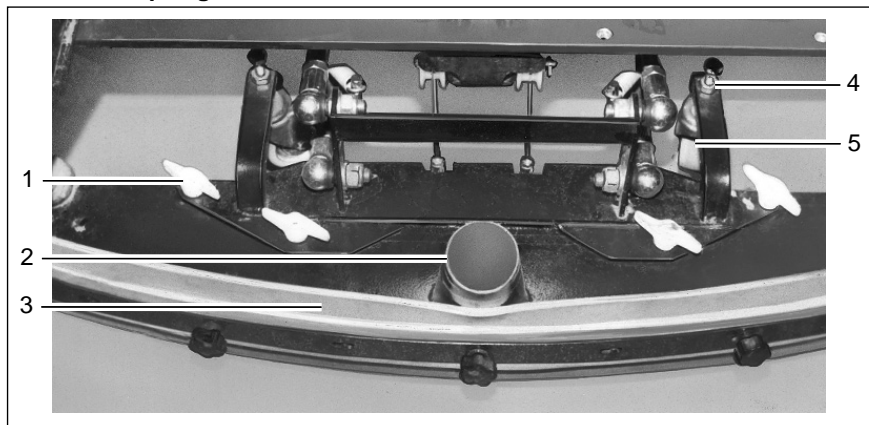

Fig. 10

Installing the squeegee

1. Switch on the key switch.
2. Lower the holding attachment of the squeegee: Press the button for the squeegee and suction turbine so that the green control lamp lights up.
3. Switch off the key switch and remove the key.
4. Open the rear doors.
5. Slide the squeegee from the rear under the lowered holding attachment and fix the squeegee to it with the four wing nuts (Fig. 10/1).
6. Attach the suction hose to the connection nozzle (Fig. 10/2) of the squeegee.
7. Insert the key in the key switch and turn the key switch on.
8. The squeegee is raised automatically.
9. Close the rear doors.

Adjusting the squeegee

The squeegee must be set up on a level floor according to the conditions in which it is to be used. The squeegee must stand vertically on the floor (adjusted at the factory). The sealing strip (Fig. 10/3) should bend slightly to the rear when the vehicle is in operation. Support rollers (Fig. 10/5) limit its movement toward the floor. These support rollers must be adjusted in order to raise the contact surface of the squeegee:

- Loosen the counter nuts (Fig. 10/4) and raise the support rollers on the left and right evenly (turn screw counterclockwise and lock again).

The sealing strip now bends a little more towards the rear. An adjustment of the support rollers is also necessary when the edge of the sealing strip is worn.

Starting Up

2.3.3 Adjusting the driver's seat

The driver's seat (Fig. 11-13) must be adjusted so that the driver is seated comfortably and can reach all the operating elements with ease.



The vehicle is equipped with a seat contact switch. The vehicle can only be operated when the operating person is seated on the seat.

The scrubber-drier is equipped with a driver's seat which can be adjusted as follows:

- according to the driver's weight,
- according to the angle of the seat backrest,
- according to the longitudinal direction (forward and back).

Adjusting to the driver's weight

Adjust the lever at the top right of the backrest:

- lighter driver, pivot the lever upwards
- heavier driver, pivot the lever downwards

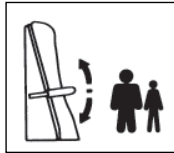

Fig. 11

Adjusting the angle of the seat backrest

Turn the knob on the bottom right of the backrest accordingly.

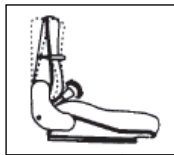

Fig. 12

Adjusting longitudinally

1. Force the lever on the right of the seat outwards slightly.
2. Slide the seat forward or back in steps of 0.6 in.

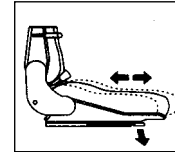

Fig. 13

Starting Up

2.4 Before starting up daily

Carry out the following checks before starting the vehicle up for its daily operation (also refer to Section 5.3.1):

1. Check the recovery tank, empty it if necessary. Clean it as necessary. Refer to Sections 5.6.1 and 5.6.2.
2. Fill the fresh water tank and add a cleaning agent in accordance with the manufacturer's mixing directives. Refer to Section 3.1.5 and Section 5.5.1.



Only use cleaning agents (non-foaming) suitable for the vehicle's vendor. We recommend using our clean and care products which are specially balanced for the vehicles.

3. Check the battery charge and recharge as necessary; refer to Section 5.4.1.



Before starting the vehicle for its first working operation, carry out an initial battery charging routine; refer to Section 2.2.

4. Check the parking space for signs of leaks. Hoses, lines and tanks must show no signs of leaks or damage. If necessary, clear up any defects before putting the vehicle into operation.

3 Operation



Operating personnel must read the operating manual through carefully. Operating personnel should complete their initial test drive on a sufficiently large piece of open space until they are familiar with the individual operating elements and the respective functions.

3.1 Method of operation

The Admiral 48D is a scrubber-drier for wet cleaning hard floors (refer to Fig. 14). It cleans floors by means of intensive scrubbing with the aid of a water and cleaning agent solution. The squeegee at the rear of the vehicle vacuums up the waste water into the recovery tank in the same working process.

By using the pre-sweep/vacuum unit, the vehicle can also be operated according to the tandem principle for the advanced sweeping and dry cleaning of hard floors: the dirt is swept up dust-free using two side brushes and a cylindrical brush.

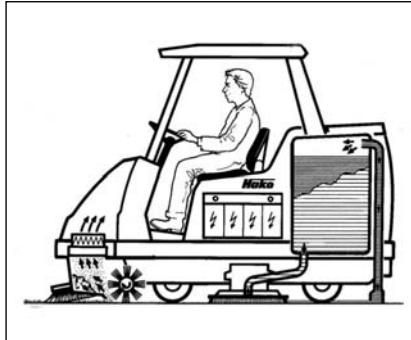

Fig. 14

The scrubber-drier is a ride-on machine designed for the economic cleaning of large floor areas in buildings. A seat contact ensures that the vehicle can only be operated when an operator is seated on the driver's seat.

The most important vehicle elements are described below:

3.1.1 Pre-sweep/vacuum unit (Fig. 15/4)

The pre-sweep/vacuum unit sweeps and vacuums up dirt in dry areas in front of the scrubbing unit without swirling up dust. In this case, the two side brushes sweep the dirt directly in the track of the cylindrical brush. The side brushes sweep up the dirt from corners and edges so that it is not necessary to drive too close to shelves, walls, machines, etc. and a driving clearance to allow steering can easily be maintained. The cylindrical brush then sweeps the dirt forwards into the dirt hopper. The fine dust swirled up by the cylindrical brush is drawn up by the extractor fan and fed to the filter element. Only clean air is blown from the machine. The Admiral 48D complies with dust category U (BIA). The pre-sweeping and vacuuming system and the filters are easily accessible for maintenance tasks.

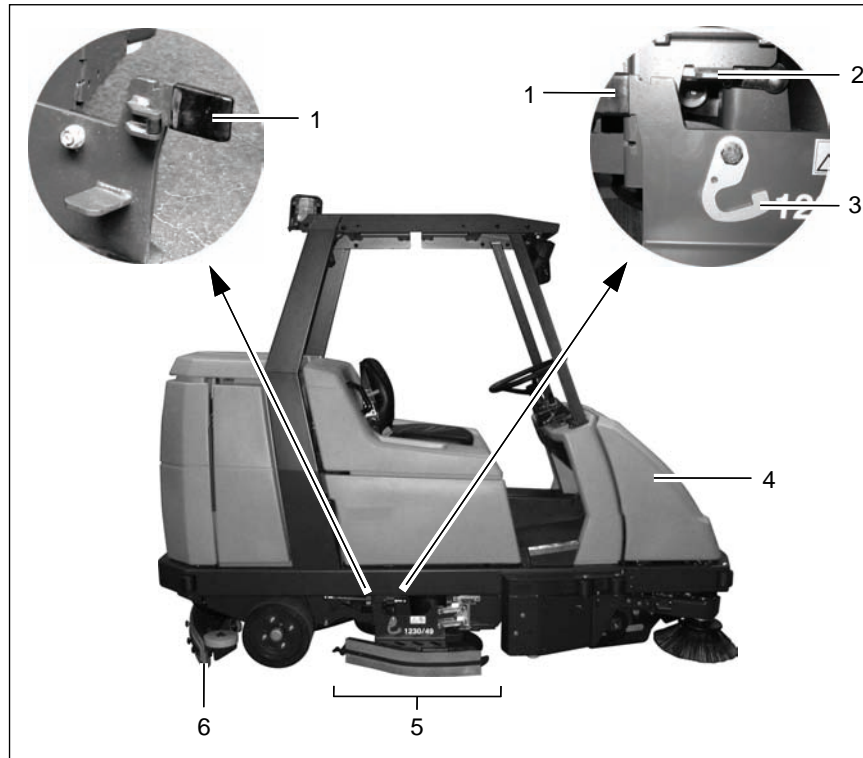

Fig. 15

3.1.2 Scrubbing unit (Fig. 15/5)

Three disk brushes, which can be changed without the need of tools, ensure a high cleaning performance. They are each driven by a brush motor. The brush pressure can be adjusted electrically according to the floor and accumulation of dirt.

When the brushes are raised, the water supply and brush rotation are stopped automatically. The deflection bars to the left and right of the disk brushes can be raised, if necessary. This ensures the cleaning solution is not forced to the center of the vehicle and, as a result, can soak the dirt. This is necessary for basic cleaning (wet scrubbing only), for example. Hook in the deflectors, refer to paragraph "Scrubbing unit".



In the case of all cleaning work involving immediate vacuuming, the deflectors must be unhooked so that the deflectors make contact with the floor.

Operation

Deflectors (Fig. 15/5)

To the right and left of the disk brushes, near the floor, are two deflectors which, when in their working position, prevent water splashing to the sides and guide the waste water to the center of the vehicle so that it can be vacuumed up better.

The deflectors can be raised, if necessary. This is the case for basic cleaning, for example, where the floor only needs to be scrubbed when wet and the solution is not vacuumed up but allowed to soak in instead. To raise the deflector, take hold of the grip (Fig. 15/1), raise it and hook the locking hooks (Fig. 15/3) in the recesses in the angle (Fig. 15/2) above it. Proceed in the same way on the other side of the side of the vehicle.

3.1.3 Squeegee (Fig. 15/6)

The squeegee, which projects at the sides, is fixed to the scrubber-drier so that it can pivot and swing. This enables it to evade obstacles in the current track and pivot back. Its strong suction capacity ensures the waste water is vacuumed up fully even on uneven floors and in bends, leaving the floor dry enough to be walked on. The squeegee must be checked prior to starting work, when disposing of waste water and/or filling the fresh water tank and cleared of any foreign bodies which have been vacuumed up.

Check that the sealing strips are in perfect condition. The rollers serve to support the squeegee to prevent excessive bending of the sealing strips. The squeegee is automatically raised when reversing.

3.1.4 Suction turbines (suction) (Fig. 16/3)

The two suction turbines are located on the rear panel of the fresh water tank and can be accessed after opening the rear doors. The suction turbines are switched on and off automatically when lowering and raising the squeegee, respectively. A float switch in the recovery tank switches the suction turbine off automatically on reaching the maximum fill height.

Operation

3.1.5 Fresh water tank (Fig. 16/2)

The fresh water tank is located behind the driver's seat on the right-hand side. The fresh water tank is a tank partitioned by a membrane panel and has a volume of approx. 81.9 gal. Open up the red tank cap and secure it to fill the tank. Fill water, max. 122 °F, and add the cleaning agent in accordance with the manufacturer's instructions. Lower the cap again to close it.



Only use cleaning agents (non-foaming) suitable for the vehicle's vendor.

We recommend using our clean and care products which are specially balanced for the scrubber drier. Observe the correct dosage of the cleaning agent. The correct dosage helps to reduce costs and protect the environment.

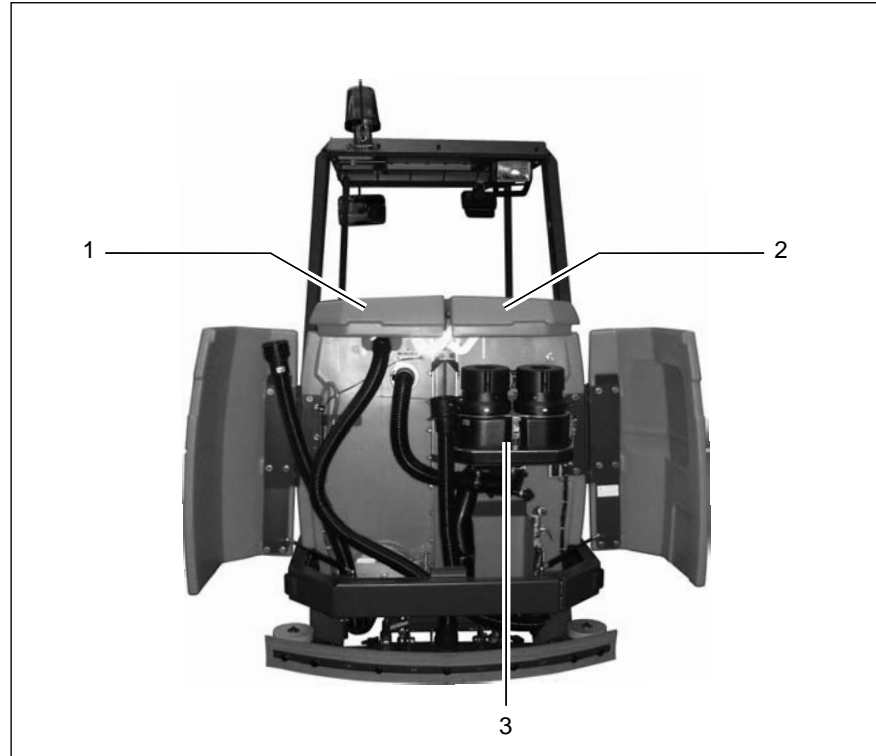

Fig. 16

Operation

The development of excessive foam impairs the vehicle's function. It indicates overdosage of the cleaning agent; components of the cleaning agent which are fed back to the waste water cause foaming. Information on dosage is provided on the cleaning agent container. Use the manufacturer's information as an initial guideline. Practical experience will ensure that you quickly find out which is the right cleaning agent and the optimum dosage to suit your needs. The fresh water supply to the brushes is automatically opened when the scrubbing program is activated. If necessary, the feed can be stopped manually by means of the ball cock. Operating times with one tankful:

- at 0.5 gal/min approx. 155 minutes
- at 1.1 gal/min approx. 77 minutes
- at 1.8 gal/min approx. 44 minutes

3.1.6 Recovery tank (Fig. 16/1)

The recovery tank is located behind the driver's seat on the left-hand side. The recovery tank is a tank partitioned by a membrane panel and has a volume of approx. 81.9 gal. The waste water is fed to the recovery tank via the squeegee by means of a vacuum. A float switch at the top of the recovery tank switches the suction turbine off automatically as soon as the maximum tank fill level is reached. In this case, the control lamp (Fig. 19/2) on the left operating panel lights up. An acoustic signal is also issued. A spray/vacuum tool (refer to Section 4), which can be connected to the vehicle, is optionally available with which to clean and vacuum up water from areas difficult to access.

Operation

3.1.7 Traction drive

The traction drive is provided by a drive motor on the steerable front wheel. The driving speed can be continuously regulated via the accelerator by means of the electronic drive control (pulse contact control). The axle gear is a gear train which runs in an oil bath.



In the case of faults involving the traction drive, stop the vehicle immediately and remove the key from the key switch!

3.1.8 Brakes

The scrubber-drier is equipped with a service brake and a parking brake. The service brake relates to a drum brake which acts hydraulically on the rear wheels. It is actuated by a foot pedal. The parking brake is actuated mechanically via brake cables. It is applied by means of the foot pedal to the left of the steering column and released using the safety catch in the steering column.

Operation

3.1.9 Batteries and charger

The scrubber-drier is powered by a traction battery (36 Volt / 395 Ah₅), 6 monobloc batteries each producing 6 Volt. They are fit in a battery tray. To ensure protection against deep discharge, the scrubber drier is equipped with a deep discharge signal transducer (Battery Management System (BMS)). It is integrated in the electronic system and set up at the factory for GiS batteries (service indicator: No. 5).



If other batteries are used, the deep discharge signal transducer must be adjusted. This adjustment work should only be performed at an authorized PowerBoss service center.

The battery is provided with a connection cable with battery plug (Fig. 17/1). When the battery plug is plugged into the vehicle socket (Fig. 17/2), the vehicle is ready to operate.

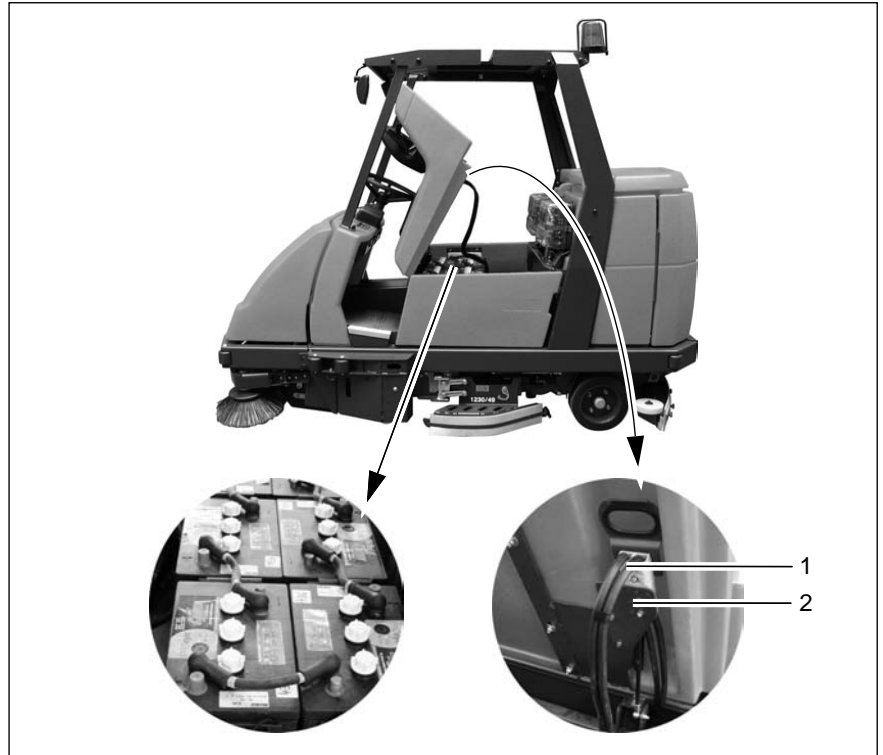

Fig. 17

Operation

In order to charge the battery, the battery plug must be plugged into an adapter and the adapter connected to the charger.

The vehicle includes an adapter comprised of two plugs connected by a 11.8 in long piece of cable.



The adapter belongs to the scope of delivery of the vehicle.



The battery charger is not contained in the scope of delivery of the vehicle.



Only use an appropriate charger!

Pay attention to the safety information enclosed with each battery.

3.1.10 Options

- 1 Working lights
- 2 Cab safety roof
- 3 Flashing beacon
- 4 Spray/Vacuum tool
- 5 Side brush collision protection
- 6 Side collision protection
(not assembled in the illustration)

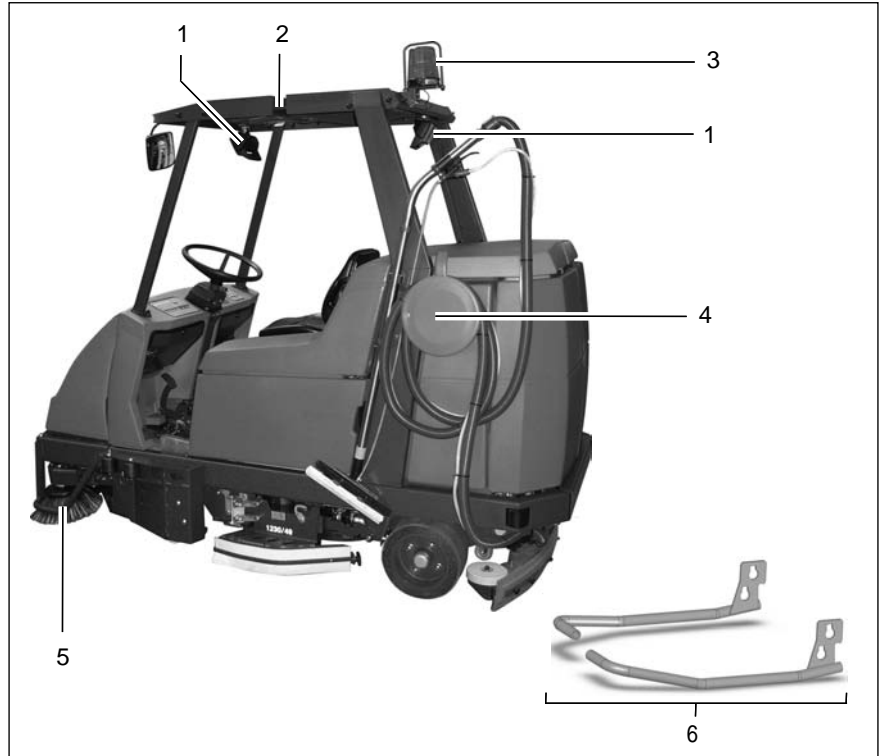

Fig. 18

Operation

The basic vehicle can be supplemented by further components. The order and spare parts numbers of these components are in brackets.



Please refer to our spare parts catalogue in Internet under www.powerboss.com for information on accessories such as brushes, pads, drive plates with centerlock etc.

- **Working lights**

(Fig. 18/1) (7584.02)

Area of use: To enable use of the vehicle even in badly lit areas.

- **Cab safety roof**
(Fig. 18/2) (7582)

Area of use: To protect the driver, e.g. from parts which could fall from high rack warehouses. Including rear-view mirror.



Pay attention that assembly of a cab safety roof is made compulsory when the vehicle is operated in such risk areas.

- **Flashing beacon**
(Fig. 18/3)

(7585.02 Assembly on cab safety roof)

(7585.10 Assembly on pole / without cab safety roof)

Area of use: To improve awareness of the vehicle when in use.

- **Spray/Vacuum tool**
(Fig. 18/4)

Area of use: Areas which are difficult to access can be cleaned manually with a spraying and vacuuming tool. A holder can be installed on the left-hand side of the vehicle to fix the spray/vacuum tool. Two holes are already drilled in the left-hand side of the vehicle for this. The following belong to the spray/vacuum tool:

- **Floor scrubbing tool** (7009)
- **Suction and spraying hose** (7766)

- **Tool holder and attachment parts** (7311.10)

The corresponding buttons are provided on the left operating panel with which to **operate the spray/vacuum tool:**

- **Vacuuming tool on/off switch:**
Press the button to switch the fresh water supply on and off (Fig. 21/14).
- **Press the reduce fresh water quantity button** (Fig. 21/13) or **increase fresh water quantity button** (Fig. 21/15) to set the required water quantity, also refer to Section "Keypad to control the

Operation

- fresh water supply“ (Fig. 21/12).
- Press the squeegee and suction turbine button (Fig. 21/10) to switch the suction turbine on or off.



When the spray/vacuum tool is in operation, the scrubber-drier's parking brake must be applied.



The spray/vacuum tool only functions when nobody is sitting on the driver's seat and the parking brake is applied.

- **Hand-held vacuum cleaner (Fig. 18/4)**

Area of use: For vacuuming up water manually in areas which are difficult to access.

The hand-held vacuum cleaner can be fixed to the tool holder (refer to spray-vacuum tool).

The hand-held vacuum cleaner contains:

- **Adapter** to connect the following tools (7893)
- **Suction hose** (flexible plastic extension hose), length: 9.8 ft (7880)
- **Suction pipe** (for connection to the plastic extension hose), length: 4.3 ft (7881)
- **Suction nozzle** with rubber lips (7883)

Operation of the hand-held vacuum cleaner: refer to Spray/Vacuum Tool, page 36.

- **Side brush collision protection (Fig. 18/5)**
(7581.50)

The collision protection for the two side brushes on the pre-sweep/vacuum unit consists of two angled steel bars which can be assembled at the front left and front right of the pre-sweep/vacuum unit (Fig. 15/4) and protect the scrubber-drier from damage caused by collisions.

- **Side collision protection (Fig. 18/6)**
(7680.30)

The side collision protection consists of two steel bars which can be assembled on the right and left-hand sides of the vehicle at the height of the disk brushes and deflectors to protect the scrubber drier from damage cause by collisions. The side collision protection can be disassembled quickly without the need of any tools.

Operation

Chemical dosing system

(Fig. 19/1) (7564.02)

The chemical dosing system adds a chemical cleaning agent to the fresh water. The chemical cleaning agent is in a canister (Fig. 19/2) and is not part of the scope of delivery of the chemical dosing system.

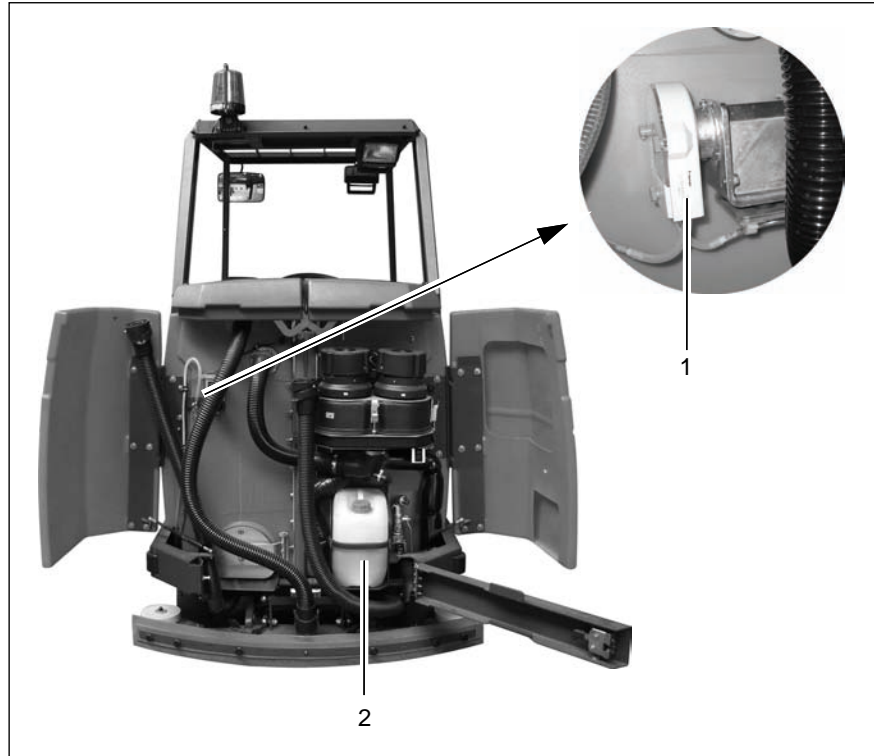

Fig. 19

Operation

3.2 Operating and indicator elements

3.2.1 Operating elements in the driver's cab

- 1 Steering wheel
- 2 Left-hand operating panel
- 3 Safety catch (to release the parking brake)
- 4 Parking brake
- 5 Direction switch (forwards/reverse)
- 6 Right-hand operating panel
- 7 Service brake
- 8 Accelerator pedal for speed control of forward and reverse drive

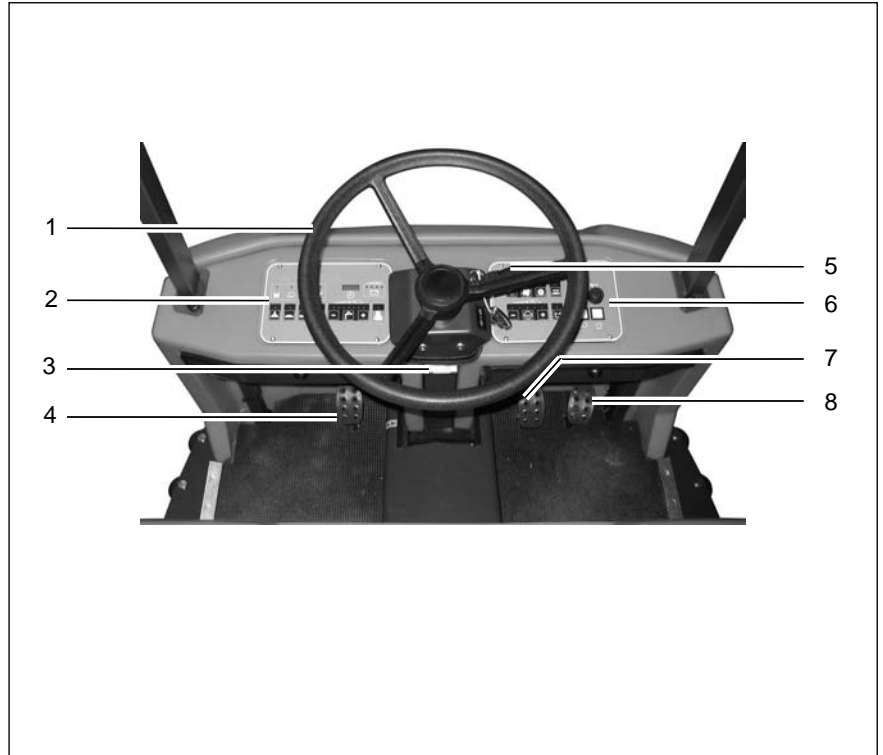

Fig. 20

Steering wheel

(Fig. 20/1)

- The scrubber-drier is steered by the steering wheel.

Left-hand operating panel

(Fig. 20/2)

- This operating panel contains all the buttons for the electronically controlled, standard cleaning programs.
- Individual functions can be added or removed from the cleaning process, as necessary.
- All the buttons are provided with clearly descriptive labels.
- The green control lamps in the operating buttons serve as function indicators.
- The significance and functioning method of the individual buttons on this operating panel is described in paragraph 3.2.2.

Safety catch

(Fig. 20/3)

- The safety catch serves to release the parking brake when applied.
- Operating sequence to release brake:
 - Tread on the pedal slightly.
 - Press the catch down.
 - Release the pedal.

Parking brake

(Fig. 20/4)

- The pedal to the left of the steering column serves to apply the parking brake to the rear wheels.
- When the parking brake is applied, the corresponding control lamp on the operating panel (Fig. 21/4) lights up red.
- If the driving direction switch is actuated while the parking brake is applied, an intermittent "beep" is issued.



Before getting out of the vehicle apply the parking brake, set the driving direction switch (Fig. 20/5) to its neutral position and switch the key switch to off.

Drive direction switch

(forwards/reverse)

(Fig. 20/5)

- It serves to select the driving direction:
 - Forward: control switch forward
 - Reverse: control switch back
 - Stop: control switch in center (neutral position)
- To change the driving direction, stop the vehicle by applying the service brake, select the new direction and accelerate again.

Right-hand operating panel (Fig. 20/6)

- This operating panel contains the key switch to switch the vehicle on and off, the horn and a range of switches to operate the optional equipment, also refer to paragraph 3.2.3.

Service brake (Fig. 20/7)

- In order to slow the vehicle down and bring the scrubber-drier to a stop, tread on the foot pedal to the left of the accelerator (as with a normal vehicle) to actuate the hydraulic service brake.

Accelerator to drive forwards and backwards (Fig. 20/8)

- The pedal on the right serves to control the driving speed (as in a normal vehicle).
- Before actuating the accelerator, use the driving direction switch (Fig. 20/5) to set the direction of travel: forwards or reverse.
- Forwards or reverse (according to the driving direction switch setting): Press the accelerator forward and down slowly.
- Release the pedal: The speed is automatically reduced, slowly. The vehicle rolls to a stop until reaching its zero setting.
- To stop securely, apply the service brake (Fig. 20/7).
- The speed for forward drive is approx. 5.0 mph and for reverse drive approx. 2.5 mph.
- The working speed when the brushes are switched on, the squeegee is lowered and pre-sweep/vacuum unit is approx. 4.4 mph.



An acoustic warning signal (buzzer) is issued should the drive motor overload. At the same time, the red alarm lamp (Fig. 20/5) lights up in the left-hand operating panel (Fig. 21/2) and the driving speed is reduced by approx. 50%. In addition, an error code appears in the service indicator (Fig. 21/6).

Operation

3.2.2 Left-hand operating panel

(Fig. 21)

- 1 Indicator field
- 2 Recovery tank indicator: When the control lamp is on (yellow), the maximum fill level has been reached.
- 3 Dirt hopper and front flap indicator of the pre-sweep/vacuum unit
- 4 Parking brake indicator: When the control lamp is on (red), the brake is applied.
- 5 Alarm indicator: When the control lamp is on (red), a functional fault has occurred.
- 6 Operating hour counter and service indicator
- 7 Battery and charge control indicator
- 8 Button for brush pressure
- 9 Button for brush drive
- 10 Button for squeegee and suction turbine
- 11 Button for simultaneous activation of the scrubbing unit and vacuuming function
- 12 Buttons for controlling the fresh water supply

- Continued on next page -

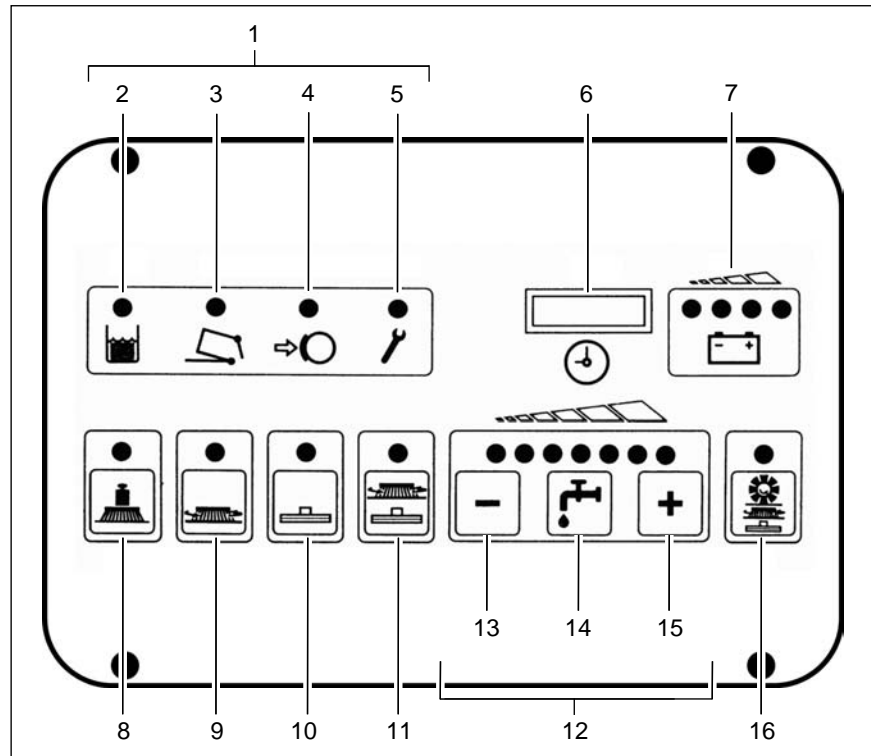

Fig. 21

Operation

- Continued -

- 13 Button to reduce fresh water quantity
- 14 Button to switch fresh water supply on and off
- 15 Button to increase fresh water quantity
- 16 Button for simultaneous activation of pre-sweep/vacuum unit, scrubbing unit and vacuuming function

Indicator field

(Fig. 21/1) The indicator field enables the scrubber-drier to provide feedback on the operating status of the vehicle. This only relates to operating states which cannot be switched on and off via the operating panel: recovery tank full, dirt hopper for pre-sweep/vacuum unit full, parking brake applied and error message.

The individual buttons and functions are described in detail below:



Indicator for recovery tank maximum fill level

(Fig. 21/2) The yellow control lamp lights up when the recovery tank has reached its maximum fill level. Also, a "beep" signal is issued every 15 seconds. In this case, a float switch switches the suction turbine off and the squeegee is raised.



Dirt hopper and front flap indicator of the pre-sweep/vacuum unit

(Fig. 21/3) The control lamp lights up red when the dirt hopper is not properly inserted (engaged) or the front flap is not properly closed.



Indicator for parking brake applied

(Fig. 21/4) The control lamp lights up red when the parking brake has been actuated via the pedal to the left of the steering column. If the traction drive is switched on, an acoustic signal is also issued.

Operation



Indicator for function faults

(Fig. 21/5)

The control lamp lights up red when one of the following

faults occurs:

- Thermostatic switch of the brush motor, drive motor or cylindrical brush has switched off
- One of the safety fuses is defective or an electronic fuse has been tripped.
- Another fault has occurred.

At the same time, a four-digit code appears in the display of the service indicator (Fig. 21/6). This error code infers which fault has occurred (refer to Section 3.5.1). At the same time, the control lamps flash and an acoustic signal is issued.

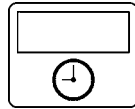

Operating hour counter

(Fig. 21/6) The four-digit LED serves to display the operating hours.

When the key in the key switch is turned on, one and then two four-digit codes appear in succession (for further details, refer to page 48, Key switch (Fig. 22/6)). The operating hours appear after this.

The counter only operates when consumers are switched on (e.g. drive or brush motor, suction turbine or pre-sweep/vacuum unit). At the same time, a red dot flashes at the bottom right of the display.

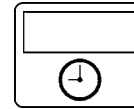

Service indicator

(Fig. 21/6) The four-digit LED serves for a more accurate determination of function faults. If a

fault occurs during operation, a four-digit code (error code) appears in the service indicator display. At the same time, the four dots of the error code flash in the display and an acoustic signal is issued. The control lamp indicating functional faults lights up red. Section 3.5.1 provides an overview of the error codes which help you clear functional faults yourself. Clear the fault before starting to use the vehicle again. If you cannot clear the fault yourself, note down the error code and inform the authorized PowerBoss dealer responsible for your vehicle.

Operation

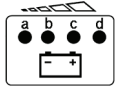

Battery and charge control indicator (Fig. 21/7)

After switching on the key, all four lamps light up when the battery is fully charged. As the battery is discharged during operation, the three right-hand lamps indicate the level of discharge by going out in sequence from right to left. When the left, red lamp flashes, it indicates that work must come to an end. Approximately three minutes later, the brushes will return to their home position. After a further three minutes, the suction turbine is deactivated and the squeegee is raised. When the red lamp lights up continuously, approximately one minute remains until the entire vehicle shuts down automatically.



Drive back to the charger in good time. Take the distance to the charger into account.



Button for brush pressure (Fig. 21/8) This button is used to increase the brush pressure. This may be necessary when the area to be cleaned is extremely dirty.

The pressing force can be increased to max. 205 lbs. If the function is active, the green control lamp lights up.



Working with an increased brush pressure also means increased brush wear. Therefore, only press this button when necessary.

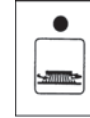

Button for the brush drive (Fig. 21/9) This button serves to switch the brushes and fresh water supply on and off with simultaneous, respective lowering and

raising of the brush head. If the function is active, the green control lamp lights up.

Operation

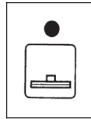

Button for squeegee and suction turbine

(Fig. 21/10) This button serves to switch the suction turbine on and off with simultaneous lowering and

raising of the squeegee. If the function is active, the green control lamp lights up.



This button must also be pressed when working with optional tools connected to a suction hose. Operating personnel must not be seated on the driver's seat in this case (seat contact is bypassed). Only the suction turbine is activated at this point, the squeegee remains raised.

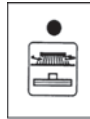

Button for simultaneous activation of the scrubbing unit and vacuuming function

(Fig. 21/11) After pressing

the button, the most important basic functions for standard cleaning are automatically activated/deactivated in the correct sequence of use: suction turbine, brush rotation, fresh water supply and lowering or raising the brushes and squeegee. When the vehicle is ready for use in accordance with requirements, it can be set into operation simply and quickly by pressing the button. When the button has been pressed, the green control lamp lights up.

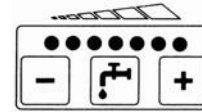

Buttons controlling the fresh water supply

(Fig. 21/12) The

fresh water consumption used during cleaning can be regulated in seven stages. Accordingly, there are seven green control lamps on the keypad. Each lamp relates to one stage. The maximum quantity which can be used for cleaning is 2.0 gal/min (all seven lamps are on). The minimum quantity is 0.3 gal/min (only the left lamp is on). The last fresh water quantity selected is always used. When the scrubbing program is switched on for the first time, a fresh water quantity of approx. 0.9 gal/min is automatically set.

Operation

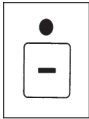

Button to reduce fresh water quantity

(Fig. 21/13) The button serves to reduce the fresh water quantity supplied to the brushes. The fresh water quantity can be reduced in seven stages (see above). The stage selected remains programmed, even if the vehicle is switched off in the meantime.



Button to switch the fresh water supply on and off

(Fig. 21/14) This button serves to switch the fresh water supply on and off when the brush head is lowered or when using the spray/vacuum tool. The water quantity previously set remains unchanged.

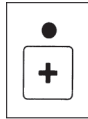

Button to increase fresh water quantity

(Fig. 21/15) The button serves to increase the fresh water quantity supplied to the brushes. The fresh water quantity can be increased in seven stages (see above). The stage selected remains programmed, even if the vehicle is switched off in the meantime.



Button for simultaneous activation of pre-sweep/vacuum unit, scrubbing unit and vacuuming function

(Fig. 21/16) This button serves for simultaneous activation/deactivation of the pre-sweep/vacuum unit, brushes, suction turbine and water supply as well as lowering or raising the cylindrical brush including side brush, brushes and squeegee.

Operation

3.2.3 Right-hand operating panel (Fig. 22)

- 1 Operating buttons for pre-sweep/vacuum unit
- 2 Button for agitating device
- 3 Button for extractor fan
- 4 Button to switch pre-sweep/vacuum unit on and off
- 5 Button has no function
- 6 Key switch
- 7 Horn
- 8 Buttons for chemical dosage option
- 9 Reduce quantity of cleaning agent
- 10 Button to switch chemical dosage option on/off
- 11 Increase quantity of cleaning agent
- 12 Button has no function
- 13 Switch for working lights
- 14 Switch for flashing beacon

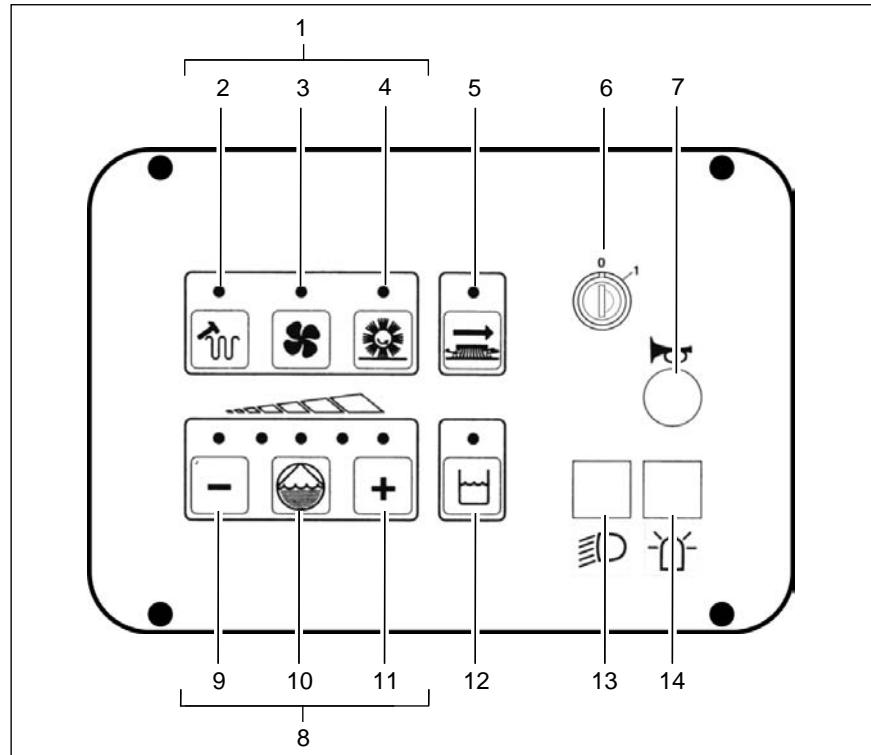

Fig. 22

Operation



If optional accessories are not assembled, the corresponding buttons have no function.



Button for agitating device (Fig. 22/2)

This button serves to switch an agitation process on and off, whereby the filter system on the pre-sweep/vacuum

unit is cleared of the dust attached.

After pressing the button, an agitation process runs for approx. 6 seconds in intervals; press the button again to end the process prematurely. Alternatively to pressing the button, you can turn the key switch to position 0 and 1 (RESET).

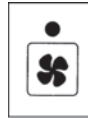

Button for extractor fan (Fig. 22/3)

This button serves to switch the extractor fan of the filter system on and off. The filter system is part of the pre-sweep/vacuum unit.



Button to switch the pre-sweep/vacuum unit on and off (Fig. 22/4)

This button is used to switch the pre-sweep/vacuum unit on and off.

Operation

Key switch

(Fig. 22/6)

It serves to switch the electrical installations on and off and to secure the vehicle against unauthorized use.

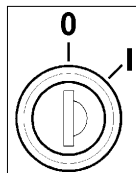

When the key switch is switched on (lock position 1), the following appear in the operating hour counter display (left-hand operating panel, refer to "Operating hour counter" in paragraph 3.2.2):

1 Software version

Displayed for approx. 1 second.

Example:



2 Error code

Indicates the error code of the last fault which occurred and is displayed for approx. 2 seconds. The display serves as information for the service technician so that the fault can be cleared quickly. For an overview of the error codes, refer to Section 3.5.1.

Example:

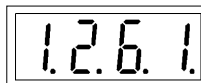

When a functional fault actually occurs, an acoustic signal is also issued and the red control lamp on the alarm indicator (Fig. 21/5) lights up.

3 Operating hour indicator

Continual display.

Example:

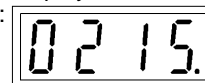

During operation, the dots flash in the display.

4 Control digits (optional)

In the case of brand new vehicles, it is possible that after switching on the key switch, this display also appears:

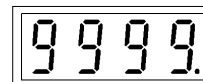

The control digits are for internal control purposes. The display changes to zero operating hours after one hour at the latest. The scrubber-drier is ready for use while this display appears. The alarm indicator is activated.

Operation

Horn

(Fig. 22/7)

An acoustic warning signal is issued on actuating the horn knob.



Button for reducing the quantity of cleaning agent (Fig. 22/9)

On pressing this button, the amount of cleaning agent added to the fresh water is reduced.



Button to switch chemical dosage option on/off (Fig. 22/10)



The chemical dosage can only be switched on when the fresh water supply has been switched on beforehand (Fig. 21/14).



Button for increasing the quantity of cleaning agent (Fig. 22/11)

On pressing this button, the amount of cleaning agent added to the fresh water is increased.

Switch for working lights (Fig. 22/13)

This switch switches the working lights on or off. This occurs even without the key switch being turned on.

The working lights are optional accessories.

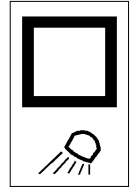

Switch for flashing beacon (Fig. 22/14)

The flashing beacon is an optional accessory.

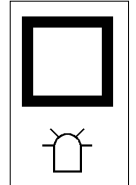

Operation

3.2.4 Operating elements on the vehicle

- 1 Opening between the waste and fresh water tank.
- 2 Filter sieve
- 3 Fresh water tank filling neck
- 4 Lid lock
- 5 Cover, recovery tank
- 6 Cover, fresh water tank
- 7 Rear door, right
- 8 Rear panel frame
- 9 Rear door, left
- 10 Fresh water draining hose
- 11 Waste water draining hose
- 12 Rear panel frame lock

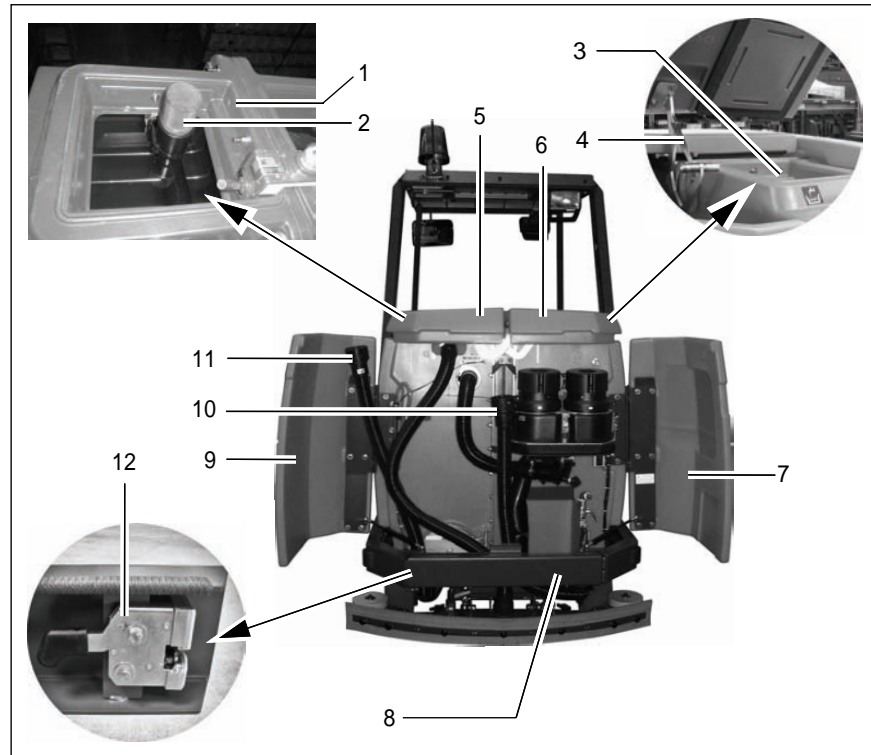

Fig. 23

Operation

Recovery tank

(Fig. 23/2+5)

The air intake filter (Fig. 23/2) is located under the recovery tank lid (Fig. 23/5) at the top of the recovery tank and is connected to the end of the suction pipe. It prevents coarse dirt getting into the suction turbines and must be checked or cleaned daily, refer to Section 5.6.4.

Fresh water tank

(Fig. 23/3+6)

In order to fill fresh water and cleaning agent, pivot up the lid of the fresh water tank (Fig. 23/6) and lock it. The tank is filled through the filling neck (Fig. 23/3), refer to Section 5.5.1.

Lid lock

(Fig. 23/4)

The lock prevents the lid falling shut. To lock the lid, move the bar and latch in place. To release the lock, raise the lid a little and pivot the lock back a little. The lid lock functions in the same way on the fresh water tank and recovery tank.

Rear doors

(Fig. 23/7+9)

Open the rear doors to access the draining hoses for waste water and fresh water.

Waste water draining hose

(Fig. 23/11)

The draining hose for waste water hooked is in the left-hand rear door. Only drain off waste water through this hose at an appropriate location, refer to Section 5.6.1.

Fresh water draining hose

(Fig. 23/10)

The draining hose for fresh water hangs to the left of the suction turbines. Only drain off the fresh water through this hose at an appropriate location, refer to Section 5.5.2.

Rear panel frame

(Fig. 23/8+12)

In order, for example, to access the flap to clean the recovery tank, the rear panel frame must be opened. To do this, pull the lock lever (Fig. 23/12) up and open the unlocked rear panel frame (Fig. 23/8).

Operation

- 13 Seat console
- 14 Electrical compartments
- 15 Side door



Fig. 24

Seat console

(Fig. 24/13)

The driver's seat is mounted on the seat console. The seat console can be pivoted up using the handle in order to access the batteries and electric system.

Electrical compartments

(Fig. 24/14)

In the driver's cab, to the left and right of the steering column, are two electrical compartments which must be opened by means of a special square wrench.



The electrical compartments are not provided in the sense of glove compartments.

Side door

(Fig. 24/15)

The side doors are located to the left and right of the battery. The doors must be pivoted open in order to change the batteries, refer to Sections 5.4.3 and 5.4.4.

Operation

3.3 Operation

The scrubber-drier can be operated on surfaces with a gradient of 6% for maximally 3 minutes.



The climbing capacities stipulated in this manual can and may only be achieved with the battery specified in the Section „Technical Data“.



Adapt your driving style to the local conditions (floor characteristics, persons in the vicinity, obstacles etc.).



When cleaning on slopes, the traction may be impaired.

3.3.1 Switching the vehicle on

Please read Section 1 before switching the vehicle on.



Carry out the following steps so that the vehicle is ready to operate:

- Disconnect the battery plug from the charger and connect it to the vehicle.



When connecting the battery plug to the vehicle, switch the key switch to off (lock position 0) beforehand.

- The vehicle is equipped with a safety shutdown via a seat contact. This means that it is essential for operating personnel to be seated in the driver's seat to be able to operate the vehicle.
- Ensure that the driving direction switch is in its neutral setting, refer to "Accelerator for driving forwards and backwards" in Section 3.2.1.

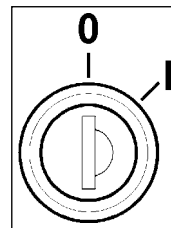

Fig. 25

- Actuate the service brake with your foot in order to prevent accidentally accelerating the vehicle, refer to "Service brake" in Section 3.2.1.
- Insert the key in the key switch (Fig. 25).
- Turn the key from lock position 0 to position 1. The vehicle is ready to operate.

Operation

3.3.2 Accelerating

- Set the required driving direction with the direction switch: set the switch to the front to drive forward, set the switch to the rear to reverse.
- Release the parking brake, refer to "Safety catch" in Section 3.2.1.
- Press the accelerator down slowly with your right foot until you reach the required driving speed.

3.3.3 Stopping and parking

- Remove your right foot from the accelerator to slow down. When the foot is fully removed from the accelerator, the vehicle rolls to a stop.
- Now press the right foot on the service brake pedal to stop the vehicle and bring it to a stop.
- Turn the key in the key switch counterclockwise to lock position 0 and remove the key.
- Press the left foot on the parking brake pedal to park the vehicle.



Always apply the parking brake and remove the key before getting out of the vehicle!

3.3.4 Cleaning

If the hand-held vacuum cleaner or spray/vacuum tool option is assembled, there are a total of six cleaning programs available for selection:

1. Sweeping
2. Sweeping, wet scrubbing and vacuuming dry
3. Wet scrubbing and vacuuming dry
4. Wet scrubbing (basic cleaning)
5. Vacuuming dry
6. Working using the additional scrubbing and vacuuming tool (spray/vacuum tool) / vacuuming with the suction hose (option)

The cleaning programs are activated via the left-hand operating panel, refer to Section 3.2.2. Press the relevant button as soon as the scrubber-drier is ready to operate (see above).

Operation

Sweeping

- Press the "Button for pre-sweeping the pre-sweep/vacuum unit on/off" (Fig. 22/4) on the right-hand operating panel.



Various functions can be switched on or off with the following buttons:

- Switch extractor fan on/off (Fig. 22/3)



If the ground is wet, always switch the vacuum fan off!

- Actuate the agitating device (Fig. 22/2)



Once a day with normal use.

Sweeping, wet scrubbing and vacuuming dry

This program is the standard cleaning program.

- Press the "Button to switch the pre-sweep/vacuum unit, scrubbing unit and vacuum on simultaneously" (Fig. 21/16) on the left-hand operating panel.



Various functions can be switched on or off with the following buttons according to the conditions at the location of use:

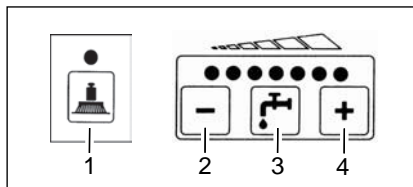

Fig. 26

- Increase brush pressure (Fig. 26/1)
- Fresh water feed on/off (Fig. 26/3)
- Reduce fresh water quantity (Fig. 26/2)
- Increase fresh water quantity (Fig. 26/4)

Wet scrubbing and vacuuming dry

This program is a standard cleaning program for this vehicle.

- Press the "Button to switch the scrubbing unit and vacuum on simultaneously" (Fig. 22/11) on the left-hand operating panel.

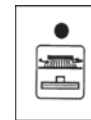

Various functions can be switched on or off with the following buttons according to the conditions at the location of use:

- Increase brush pressure (Fig. 26/1)
- Fresh water supply on/off (Fig. 26/3)
- Reduce fresh water quantity (Fig. 26/2)
- Increase fresh water quantity (Fig. 26/4)

Operation



Check whether the floor is sufficiently dry at regular intervals, otherwise people could slip. If the floor is excessively wet, check the vehicle for leaks and that the sealing strips are in a good condition. If the sealing strips are damaged, change them; refer to Section 5.8.4.

Wet scrubbing (basic cleaning)

If you do not want to vacuum the floor dry in the same working procedure because you want the solution to soak into the dirt, for example, activate this program.



Wet floors are a potential risk for slipping! Ensure to provide the corresponding information and warning signs.

- Press the “Button for the brush drive” (Fig. 21/9) on the left-hand operating panel.

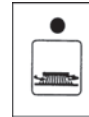

Various functions can be switched on or off with the following buttons according to the conditions at the location of use:

- Reduce water quantity (Fig. 26/2)
- Increase water quantity (Fig. 26/4)
- Fresh water feed on/off (Fig. 26/3)
- Increase brush pressure (Fig. 26/1)

Vacuuming dry

- Press the “Button for squeegee and suction turbine” (Fig. 21/10) on the left-hand operating panel.

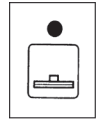

Check whether the floor is sufficiently dry at regular intervals, otherwise people could slip. If the floor is excessively wet, check the vehicle for leaks and that the sealing strips are in a good condition. If the sealing strips are damaged, change them; refer to Section 5.8.4.

Operation

Vacuuming with the suction hose

The suction hose is an optional accessory and part of the spray/vacuum tool function.



When the suction hose is in operation, the scrubber drier's parking brake must be applied.



Vacuuming with the suction hose only works when the operator is not seated on the driver's seat (seat contact switch is not actuated) and the parking brake is applied.

1. Press the "Button to switch the fresh water supply on and off" (Fig. 21/14) on the left-hand operating panel to switch the water on and off.



2. Press the "Button for squeegee and suction turbine" (Fig. 21/10) on the left-hand operating panel to switch the suction turbine on and off.

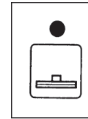

The squeegee remains raised.

Useful tips for cleaning

- Sweep the floor before starting wet cleaning. This not only improves the cleaning effect but also reduces the vehicle's liability to wear.
- The floor should be treated twice in the case of particularly dirty floors or to remove wax (basic cleaning).
 - During the first cleaning process, the floor is scrubbed with a cleaning agent dosage appropriate to the degree of soiling, whereby the squeegee is raised.
 - Let the cleaning solution work into the floor for 5 to 10 minutes according to the manufacturer's information.
 - Then scrub the floor again with the squeegee lowered.
- Observe the correct dosage of the cleaning agent. Information on dosage is provided on the cleaning agent container.
- Use the manufacturer's information as an initial basis. Practical experience will ensure that you quickly find out which is the right PowerBoss cleaning agent and the optimum dosage to suit your needs.

Operation



The correct dosage helps to reduce costs and protect the environment.



The development of excessive foam impairs the vehicle's function.

Cause: Too much cleaning agent leads to certain component parts of it getting into the waste water resulting in the development of foam. This indicates that the amount and mixture of solution do not match the level of dirt.

3.3.5 Switching the vehicle off



Apply the parking brake!

1. Turn the key from position 1 to lock position 0. The vehicle is no longer ready to operate.
2. Remove the key from the key switch.



Check that the working lights are switched off.

The working lights can be switched on even when the vehicle is switched off and, thus, drain the battery.

3.3.6 Loading and transporting the vehicle

Refer to Section 5.13.

Operation

3.4 After finishing work

1. Drive to a suitable service or parking area.



An appropriate service and parking area must have a solid floor, have a roof and ensure that no hazardous substances (e.g. oils, battery acid, cleaning agents, etc.) can get onto the floor or in the sewage system.

2. Stop the vehicle and switch it off.



Before getting out of the vehicle apply the parking brake, switch off the key switch and remove the key.



Check that the working lights are switched off.

The working lights can be switched on even when the vehicle is switched off and, thus, drain the battery.

3. Empty and clean the recovery tank, refer to Sections 5.6.1 and 5.6.2.



Observe the applicable laws and local regulations when disposing of cleaning agents.

4. Check the fresh water filter, refer to Section 5.5.4.
5. Check the sealing strips and suction hose, refer to Section 5.8.
6. Check the electrical equipment, functions and settings.
7. Clean the vehicle, refer to Section 5.12.



It is not permitted to clean the vehicle with a pressure washer or steam blaster.

8. Charge the batteries, refer to Section 5.4.1.



The seat console must remain open during the charging process (otherwise there is a risk of oxyhydrogen developing).



If the machine is to be shutdown for a longer period, the fresh water tank must be emptied.

Operation

3.5 Function faults



The following applies when locating and clearing faults: Switch the vehicle off, remove the key from the key switch and disconnect the battery plug!

3.5.1 Error code table

In the case of system errors, a four-digit error code appears in the left-hand operating panel in addition to the service indicator (wrench symbol).

The dots in the error/service code flash. Clear the fault or note down the error/service code and inform your authorized PowerBoss dealer.

Error code	Fault	Cause	Solution
1.2.5.2.	Brushes remain stopped because the thermostatic switch has been tripped.	The motor has overheated; foreign bodies have possibly jammed between the brush and shaft (e.g. tape and such).	<ul style="list-style-type: none">• Check the brushes for foreign bodies and remove them, as necessary.• Allow the motor to cool down.• If the problem reoccurs, determine the cause of overheating; contact an authorized PowerBoss service center, if necessary.
1.2.5.5.	Brushes remain stopped because the thermostatic switch of the third, middle brush has been tripped.	The motor has overheated; foreign bodies have possibly jammed between the brush and shaft (e.g. tape and such).	<ul style="list-style-type: none">• Check the brush for foreign bodies, remove them as necessary.• Allow the motor to cool down.• If the problem reoccurs, determine the cause of overheating; contact an authorized PowerBoss service center, if necessary.
1.2.6.1.	Brushes remain stopped because the anti-blocking system has been tripped.	Foreign bodies (e.g. tape or such) block the brushes	<ul style="list-style-type: none">• Check the brushes for foreign bodies and remove them, as necessary.

Operation

Error code	Fault	Cause	Solution
1.2.6.2.	Brushes remain stopped because the anti-blocking system of the third, middle brush has been tripped.	Foreign bodies (e.g. tape or such) block the brushes	<ul style="list-style-type: none"> • Check the brush for foreign bodies, remove them as necessary.
1.2.6.3.	The brush attachment and brush motors have been switched off because the anti-blocking system has been tripped.	Foreign bodies between the brush head and vehicle.	<ul style="list-style-type: none"> • Check the brush head for foreign bodies and remove them, as necessary.
1.4.6.1.	Squeegee holding attachment has been switched off because the anti-blocking system has been tripped	<ul style="list-style-type: none"> • Foreign bodies between the squeegee and vehicle. • Squeegee is jammed 	<ul style="list-style-type: none"> • Check the squeegee attachment for foreign bodies and remove them, as necessary • Free the squeegee.
2.2.5.1	Cylindrical brush remains stopped because the thermostatic switch has been tripped.	The motor has overheated. Foreign bodies (e.g. tape or such) possibly block the cylindrical brush.	<ul style="list-style-type: none"> • Check the cylindrical brush for foreign bodies and remove them, as necessary. • Allow the motor to cool down. • If the problem reoccurs, determine the cause of overheating; contact an authorized PowerBoss service center, if necessary.
2.2.6.1	Cylindrical brush remains stopped because the anti-blocking system has been tripped.	Foreign bodies (e.g. tape or such) block the cylindrical brush.	Check the cylindrical brush for foreign bodies and remove them, as necessary.

Operation

Error code	Fault	Cause	Solution
2.2.6.2	Cylindrical brush holding attachment has been switched off because the anti-blocking system has been tripped.	Foreign bodies (e.g. tape or such) between the cylindrical brush and machine.	Check the cylindrical brush holding attachment for foreign bodies, remove them as necessary.
2.3.6.1	The left side brush remains stopped because the anti-blocking system has been tripped.	Foreign bodies (e.g. tape or such) block the side brush.	Check the side brushes for foreign bodies and remove them, as necessary.
2.3.6.2	The right-hand side brush remains stopped because the anti-blocking system has been tripped.	Foreign bodies (e.g. tape or such) block the side brush.	Check the side brushes for foreign bodies and remove them, as necessary.
3.4.5.1	Drive motor is too hot / Drive motor switches to 50% power output.	<ul style="list-style-type: none"> • Engine is overloaded, possibly after driving up slopes. • Parking brake was actuated while driving. 	<ul style="list-style-type: none"> • Allow the motor to cool down. • Check whether the parking brake is applied and release it, if necessary.

3.5.2 Other function faults

The vehicle does not work

Check the fuses, refer to Section 5.11.3.



In the event of faults in the traction drive, stop the vehicle immediately, apply the parking brake and remove the key!

Technical Data

4 Technical Data

Dimensions		
Vehicle length (with brush head, squeegee and pre-sweep/vacuum unit)	in	103.1
Vehicle height, without/with cab safety roof	in	55.1/78.7
Vehicle width with squeegee and pre-sweep/vacuum unit	in	52.4
Vehicle width with side collision protection option	in	54.7
Working width		
Brush head	in	48.4
Squeegee	in	49.6
Pre-sweep/vacuum unit	in	54.3
Area coverage		
Theoretical at 4.4 mph	ft ² /h	92677
Weights		
Dead weight (without driving batteries, without options, without driver)	lbs	2061
Total weight operational wet (without options, without driver)	lbs	3549
Gross total weight	lbs	3968

Technical Data

Axle loads		
Ready to use, front (fresh water tank full, including cab safety roof)	lbs	1852
Ready to use, rear (fresh water tank full, including cab safety roof)	lbs	1808
Driving performance		
Driving speed, forwards/reverse	mph	5.0/2.5
Working speed, maximum, forwards	mph	4.4
Climbing capacity, transport mode (max. 15 seconds)	%	15
Climbing capacity, work mode (max. 3 min)	%	6
Turning circle diameter, outer	ft	13.9
Turning in aisle: minimum aisle width	ft	9.4
Operating time with one battery charge	h	approx. 2.5
Drive		
Drive motor (P2)	W	2000
Gear oil fill quantity	gal/SAE	0.7/SAE 90

Technical Data

Axles and wheels		
Wheelbase	in	45.3
Gauge, rear	in	34.6
Wheels, diameter/width	in	12.2/4.7
Specific wheel pressure at permissible gross total weight, front	ksi	0.178
Specific wheel pressure at permissible gross total weight, rear (left/right)	ksi	0.129/0.128
Tightening torque of wheel nuts, front/rear	lb ft	103.3/103.3
Brakes		
Service brake:		Hydraulic
Drum brakes at rear, with automatic adjustment: diameter/width	in	7.1/1.6
Brake fluid (e.g. ATE)	gal	0.1
Parking brake:		
Cable brake at rear, adjustable: diameter/width	in	7.1/1.6
Tank volume		
Membrane panel tank: fresh/waste water	gal	81.9/81.9
Flow rate, adjustable from/to	gal/min.	0.3/2.0

Technical Data

Brush head		
No. of brushes	Qty.	3
Brush diameter	in	16.9
Brush speed	rpm	210
Brush motor power output (P2)	W	3 x 710
Brush pressure, normal/increased	lbs	150/205
Specific contact pressure normal/increased	psi	0.3/0.42
Suction turbines		
Power consumption/speed	W/rpm	635/13867
Air flow rate	ft ³ /h	8476
Vacuum	psi (mmwc)	2.94 (2030)
Electrical installation		
Power supply	VDC	36
Type of current		DC
Nominal power, total	W	7600
Protection class	VDE 0700	III
Battery compartment: length/width/height	in	37.4/24.0/18.3

Technical Data

<p>Noise emission value</p> <p>The sound power level ($L_{WA(d)}$) measured according to EN 60335-2-72 under normal under working conditions is:</p> <p>The sound pressure level (L_{pA}) measured according to DIN EN 60335-2-72 (at the driver's ear) under normal working conditions is:</p> <p>Inaccuracy factor (K_{pA}):</p>	<p>dB (A)</p> <p>dB (A)</p> <p>dB (A)</p>	<p>90</p> <p>76.5</p> <p>2</p>
<p>Vibration</p> <p>The weighted, effective value of the vibration, established in accordance with ISO 5349-1 to which the upper limbs (hand-arm) are exposed under normal working conditions is:</p> <p>The weighted, effective value of the vibration and shock, established in accordance with ISO 2631-1, to which the body (feet and seat area) are exposed under normal working conditions is:</p>	<p>m/s²</p> <p>m/s²</p>	<p>< 2.5</p> <p>< 0.5</p>

Technical Data

Special equipment:		
Driving batteries		
Block battery	V/Ah ₅	6 x 6/320 (CR395)
Weight (including battery tray)	lbs	794
Chemical dosing system	Order number	7564.02
Cab safety roof (including rear-view mirror)	Order number	7582
Working lights, 2 pieces	Order number	7584.02
	V/W	2 x 24/70
Flashing beacon	V	36
For installation on the cab safety roof	Order number	7585.02
For installation on a pole (when no cab safety roof is available)	Order number	7585.10
Collision protection		
Side collision protection (2 pieces)	Order number	7680.30
Side brush collision protection (2 pieces)	Order number	7581.50

Technical Data

Special equipment:		
Additional scrubbing and vacuuming tools (spraying-vacuuming tool)		
Floor scrubbing tool	Order number	7009
Vacuuming and spraying hose (length: 16.4 ft)	Order number	7766
Tool holder and attachment part	Order number	7311.10
Additional tools for using the suction hose (hand-held vacuum cleaner)		
Adapter to connect the following tools	Order number	7893
Suction hose (length: 9.8 ft)	Order number	7880
Suction pipe (length: 4.3 ft)	Order number	7881
Suction nozzle with rubber lips	Order number	7883

Technical Data

Pre-sweep/Vacuum unit	Order number	7581
Dirt hopper volume, theoretical/practical	gal	13.2/5.3
Fill weight, maximum	lbs	60
Filter surface	ft ²	16
Use category ZH 1/487	KAT	U
Fan motor	W	234
Extractor fan, speed	rpm	3200
Air flow rate	ft ³ /h	11830
Vacuum in brush space	mmwc	8.0
Cylindrical brush drive motor (P1/P2)	W	612/550
Cylindrical brush, length/diameter	in	27.6/9.8
Cylindrical brush, minimum diameter	in	7.1
Cylindrical brush speed	rpm	510
Sweeping pattern width	in	1.2-2.0
Side brush drive motor (P1)	W	2x100
Side brush, diameter	in	15.7
Side brush speed	rpm	105

Technical Data

Special equipment:		
Brushes (total of 3 are necessary)		
5-component brush	Order number	7685
Plastic PPN 0.5 for light to medium accumulations of dirt	Order number	7806
Plastics mix K 901 for light to medium accumulation of dirt on structured floors	Order number	7816
Plastic PPN 0.8 for light to heavy accumulations of dirt	Order number	7836
SIC PA 6 grain 180 gray for basic cleaning and very heavy accumulation of dirt	Order number	7843
SIC PA 6.12 grain 120 green for basic cleaning and extreme accumulation of dirt	Order number	7845
SIC PA 6 grain 600 gray	Order number	7826
Superpads (total of 3 are necessary)		
Drive plate (pad holder) with centerlock	Order number	7857
Pads, red for routine cleaning (5 pieces in box)	Order number	7838.05
Pads, brown for routine cleaning (5 pieces in box)	Order number	7837.05
Pads, black for basic cleaning and heavy accumulations of dirt (5 pieces in box)	Order number	7840.05
Microfiber pad	Order number	7850.02

5 Maintenance and Service

General information



It is essential to pay attention to the information in Chapter "Safety Information" before completing any service or maintenance work!

By adhering to the maintenance work recommended by us, you can be sure that the vehicle is always ready to be put into operation.

Maintenance and repair work necessary on a daily and weekly basis can be carried out by a driver trained to complete the work, all other PowerBoss system maintenance may only be completed by personnel who are correspondingly qualified and trained. In case of doubt, please contact your nearest PowerBoss service center or authorized PowerBoss dealer. Failure to observe this annuls any rights to claims under the terms of guarantee in respect of resulting damage or consequential damage.

Always specify the serial number, indicated on the rating plate, when

making any inquiries and orders for spare parts, refer to Section 1.7.

5.1 PowerBoss system maintenance

PowerBoss system maintenance:

- ensures the PowerBoss working vehicle is always ready for operation (preventive maintenance),
- minimizes operating costs, maintenance and repair costs,
- ensures the vehicle has a long service life.

The PowerBoss system maintenance describes the specific technical work necessary for the individual modules and defines the intervals for the maintenance tasks. Individual parts which must be changed during maintenance tasks are defined and stipulated in spare parts kits.

PowerBoss system maintenance, customer:

Work to be carried out by the customer according to the service and maintenance instructions in the operating manual (daily and weekly). Operating personnel are given the necessary instruction by specialists when the vehicle is delivered.

PowerBoss system maintenance I:
(Every 250 operating hours or at least once a year)

Must be completed by a skilled technician in an authorized PowerBoss service center according to the vehicle-specific system maintenance with a spare parts kit.

PowerBoss system maintenance II:
(Every 500 operating hours or at least once a year)

Must be completed by a skilled technician in an authorized PowerBoss service center according to the vehicle-specific system maintenance with a spare parts kit.

PowerBoss system maintenance III/S:

(Safety check, every 1000 operating hours or at least once a year)

Must be completed by a skilled technician in an authorized PowerBoss service center according to the vehicle-specific system maintenance with a spare parts kit.

Maintenance and Service

5.2 Maintenance report

<p>Handover</p> <p>Upgrading Test drive Handover to customer Instruction completed on:</p> <p>at _____ operating hours</p>	<p>PowerBoss System Maintenance I 250 operating hours Workshop Stamp</p> <p>completed on: at _____ operating hours</p>	<p>PowerBoss System Maintenance II 500 operating hours Workshop Stamp</p> <p>completed on: at _____ operating hours</p>	<p>PowerBoss System Maintenance I 750 operating hours Workshop Stamp</p> <p>completed on: at _____ operating hours</p>
<p>PowerBoss System Maintenance III/S 1000 operating hours Workshop Stamp</p> <p>completed on: at _____ operating hours</p>	<p>PowerBoss System Maintenance I 1250 operating hours Workshop Stamp</p> <p>completed on: at _____ operating hours</p>	<p>PowerBoss System Maintenance II 1500 operating hours Workshop Stamp</p> <p>completed on: at _____ operating hours</p>	<p>PowerBoss System Maintenance I 1750 operating hours Workshop Stamp</p> <p>completed on: at _____ operating hours</p>
<p>PowerBoss System Maintenance III/S 2000 operating hours Workshop Stamp</p> <p>completed on: at _____ operating hours</p>	<p>PowerBoss System Maintenance I 2250 operating hours Workshop Stamp</p> <p>completed on: at _____ operating hours</p>	<p>PowerBoss System Maintenance II 2500 operating hours Workshop Stamp</p> <p>completed on: at _____ operating hours</p>	<p>PowerBoss System Maintenance I 2750 operating hours Workshop Stamp</p> <p>completed on: at _____ operating hours</p>

Maintenance and Service

5.3 Maintenance schedule

The following maintenance work must be completed by the customer at the intervals stipulated.

It relates to the daily and weekly maintenance work.

5.3.1 PowerBoss system maintenance, customer

Activity	Interval
	Daily
<u>Directly prior to starting operation:</u>	
Fill the fresh water tank (dose the cleaning agent, fill fresh water)	o
<u>Before or after operation:</u>	
Check the properties of the deflectors to the right and left and repair them or replace the deflector rubber (left and right) as necessary	o
Check the service brake in terms of its functionality and for signs of leaks; repair as necessary	o
Check the parking brake in terms of its functionality and for signs of leaks; repair as necessary	o
Check the squeegee is clean and for signs of damage; pay special attention that the support rollers run smoothly and for foreign bodies, clear as necessary	o

Maintenance and Service

Activity	Interval
	Daily
<u>After the end of operation:</u>	
Empty the recovery tank	o
Clean the recovery tank	o
Clean the air intake filter in the recovery tank	o
Clean the fresh water filter	o
Empty the dirt hopper on the pre-sweep/vacuum unit (several times a day, if necessary)	o
Clean the dirt hopper of the pre-sweep/vacuum unit	o
Check the battery charge; recharge as necessary	o

Maintenance and Service



Before completing the weekly maintenance work described below,

subject all the operating elements to a function test in order to check whether the vehicle is ready for operation.

Activity	Interval
	Weekly
Check the acid level of the battery and refill distilled water as necessary	o
Check the electrical system (including working lights) and repair any defects	o
Brush head: Check the deflectors on the right and left and complete any repairs or order spare parts and replace them as necessary	o
Check the squeegee, particularly the rear sealing strip, is clean and for signs of damage and wear and complete any repairs or order spare parts and replace them as necessary	o
Check the recovery tank through the inspection hole at the top for signs of premature wear (due to glass splinters, metal chips, grit, etc.) or damage and clean it	o
Check the vehicle is clean; clean it, if necessary	o
Check the brushes for signs of wear; change, if necessary	o
Complete a test drive and function test (including brake tests)	o

Maintenance and Service

5.3.2 PowerBoss system maintenance I

The following maintenance work must be completed by an authorized PowerBoss service center.

Activity	Interval
	Every 250 operating hours
Check the battery in terms of acid level, acid density and voltage per cell; clear up any defects as necessary	o
Change the gear oil in the drive motor	o
Grease the rotary joint	o
Check the service brake for leaks, check the main brake cylinder and actuating rods, clear any defects	o
Check the brake fluid in the service brake, top up as necessary, bleed (Note: brake fluid must be changed every 2 years!)	o
Subject the service brake to a brake tests; clear any defects as necessary	o
Check the parking brake for actuating play; repair as necessary	o
Subject the safety catch to a function test (to release the parking brake)	o
Check the steering for steering play and adjust as necessary	o
Lubricate and grease the steering	o

Maintenance and Service

Activity	Interval
	Every 250 operating hours
Check the torque of the wheel nuts; adjust as necessary	○
Check the scrubbing unit and service as necessary: brushes, water retaining ring, brush catches, parallel alignment of holding attachment	○
Check the deflectors on the scrubbing unit and replace them as necessary (left and right)	○
Grease the scrubbing unit joints and connecting rods	○
Check the recovery tank, particularly the lid sealing quality and filter sieve	○
Change the O-rings in the draining hose and dosing valves	○
Check the suction hose is fitted properly and for signs of damage; clear any defects as necessary	○
Test the squeegee functions: pivot, raise/lower, deflecting rollers	○
Check the front and rear sealing strips of the squeegee; change as necessary	○

Maintenance and Service

Activity	Interval
	Every 250 operating hours
Check the knurled nuts on the squeegee; change as necessary	o
Grease the joints and connection rods of the waste water vacuuming system	o
Adjust the support rollers on the squeegee	o
Check the vacuum at the suction hose; clear any defects	o
Check the electrical safety functions: parking brake, recovery tank float switch	o
Pre-sweep/vacuum unit: Check the tension and properties of the cylindrical brush drive fan belt; retension or change as necessary	o
Pre-sweep/vacuum unit: Check the cylindrical brush for signs of wear and foreign bodies (e.g. tape, wire, etc.), replace cylindrical brush if necessary	o
Pre-sweep/vacuum unit: Check the brush swings smoothly	o
Pre-sweep/vacuum unit: Check the sweeping pattern	o
Pre-sweep/vacuum unit: Check the cylindrical brush setting; adjust if necessary	o
Pre-sweep/vacuum unit: Check the sealing strips in the brush space; change any defective sealing strips	o
Pre-sweep/vacuum unit: Check side brush bristles for wear; change if necessary	o
Pre-sweep/vacuum unit: Check the filter system for leaks; disassemble the filter element and clean it, change the filter element if defective	o
Pre-sweep/vacuum unit: Check the functionality of the agitating motor and extractor fan motor	o

Maintenance and Service

Activity	Interval
	Every 250 operating hours
Check the vehicle's condition visually: color, corrosion and presence of all signs and labels	o
Check the vehicle is clean; clean it, if necessary	o
Test drive and test all function and safety-relevant component including brake tests	o
Inspection label	o
Logbook	o
On request against separate account: driver training	o

Maintenance and Service

5.3.3 PowerBoss system maintenance II

The following maintenance work must be completed by an authorized PowerBoss service center.

Activity	Interval
	Every 500 operating hours
Complete all activities in PowerBoss system maintenance I, see paragraph 5.3.2	o
In addition:	
Check the brake linings of the service brake for wear; readjust the service brake or change the brake linings as necessary	o
Check the output of the drive motor (forwards, reverse); clear defects as necessary	o
Check the carbon brushes of the drive motor; replace, if necessary	o
Check the performance of the three brush motors; clear any defects as necessary	o
Check the carbon brushes of the brush motors; replace, if necessary	o
Including visual inspection, test drive, test report, inspection label and logbook see paragraph 5.3.2	o

Maintenance and Service

5.3.4 PowerBoss system maintenance III/S (safety check)

The following maintenance work must be completed by an authorized PowerBoss service center at least once a year.

Activity	Interval
	Every 1000 operating hours
Complete all activities in PowerBoss system maintenance I and II, see paragraph 5.3.2 and paragraph 5.3.3	o
In addition:	o
Check the brake linings on the rear wheels; change as necessary	o
Change the brake fluid in the service brake (Note: brake fluid must be changed every 2 years!)	o
Check the parking brake including pedal lock and control lamp; clear any defects	o
Grease the rotary joint of the traction drive (2 lubrication points accessible from the bottom)	o
Clean carbon dust from the electric motors of the wheel brush, suction turbine and cylindrical brush drives and check the carbon brushes move easily and for signs of wear, change the carbon brushes, if necessary	o
Safety test, drive electronics	o
Including visual inspection, test drive, test report, inspection label and logbook see paragraph 5.3.2	o

Maintenance and Service

5.4 Battery system

The scrubber-drier is operated by means of a low-maintenance tray battery, refer to Sections 3.1.9 and 4. The battery is comprised of 6 individual cells (monobloc batteries) in a serial circuit.

- 1 Battery and charge control indicator (including BMS indicator) in left operating panel
- 2 Wiring diagram
- 3 Battery connection cable
- 4 Battery plug in vehicle socket
- 5 Battery plug (disconnected)
- 6 Seat console, open
- 7 Battery interconnection cable
- 8 Insulation cap

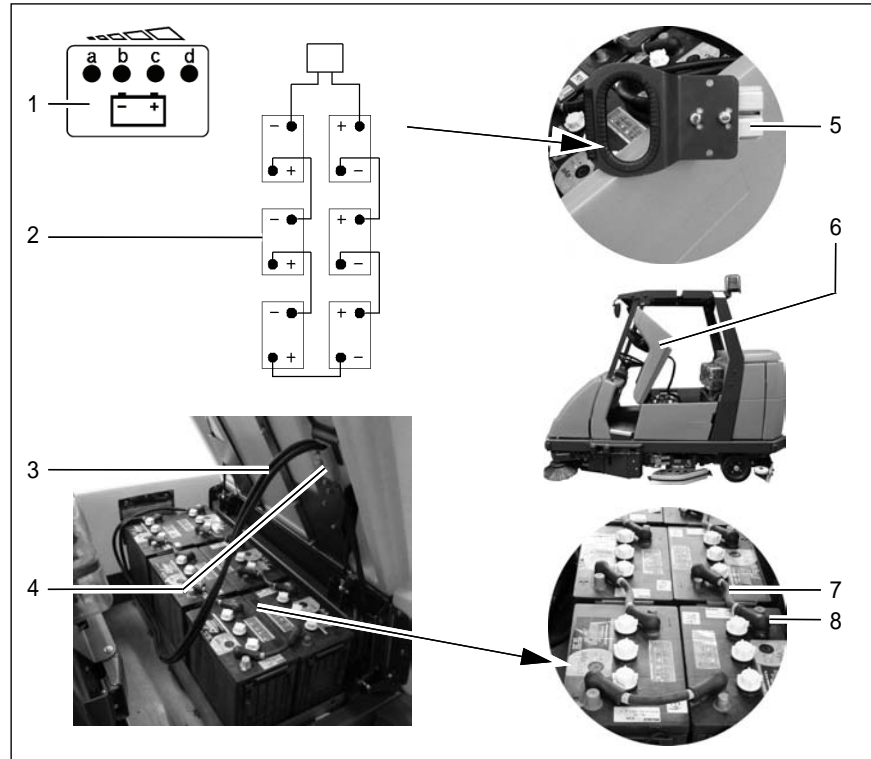

Fig. 27

Maintenance and Service

General information on handling batteries



Pay attention to the safety information in Section 1.4 and Section 1.5.2 as well as the information on servicing and maintenance in the battery documents.



Also refer to the information in the supplementary sheet 88-60-2556 "Information on driving batteries".

- Always disconnect the battery plug before starting any work on the electrical installation.
- Batteries may only be handled and changed by properly skilled maintenance personnel.
- Pay attention to legal requirements and local directives.

5.4.1 Charging batteries



Before starting the vehicle up for the first time, the batteries to be used must be properly charged by implementing the initial battery charge routine, refer to Section 2.2.

PowerBoss assumes no liability for damage to the battery caused by a fault when the battery is charged for the first time.



There must be sufficient ventilation in the charging area - risk of explosion!



The seat console (Fig. 27/6) must be open during the battery charging process to prevent the development of explosive oxyhydrogen!



Only use the original charger and original adapter! Pay attention that the insulation is not initially damaged and not damaged during the charging process. The cable must not rub against anything. Do not use the charger if the insulation

is damaged.

We recommend charging the battery when at least one dot of the battery indicator has gone out after operating the machine. The indicator (Fig. 27/5) also indicates the charge status of the batteries during the charging process.

1. Connect the battery plug (Fig. 27/4) to the adapter supplied.
2. Connect the free plug on the adapter to the battery charger.



The battery charger is not contained in the scope of delivery of the vehicle.



Pay attention to the information in the operating manual supplied with the charger and the manual from battery manufacturer.



Do not inhale battery gases.

Maintenance and Service

5.4.2 Servicing the driving batteries

Checking the acid level

The battery acid level must be checked by the customer on a weekly basis and distilled water must be topped up, if necessary; also refer to Sections 5.3.1 and 5.3.2.



There must be no naked flames used in the vicinity when handling batteries, particularly when checking the acid level.

Details on the filling process are contained in the manual provided with the water filling device.



Spilled battery acid must never enter the sewage system in its initial form, it must be neutralized beforehand: e.g. diluted with plenty of water or absorbed with granulate.

Checking the acid density and voltage of each cell

These points must be checked and corrected at regular intervals within the scope of PowerBoss system maintenance by an authorized service center.



Also refer to the information in the supplementary sheet 88-60-2556 "Information on driving batteries".

5.4.3 Disassembling the battery

1. Park the vehicle on a level area of floor.



Turn the key switch to position 0 and remove the key.

2. Open the side doors to the left and right (Fig. 28/3).
3. When you are positioned on the right-hand side of the vehicle, take hold of the seat console at the handle (Fig. 28/2) and pivot up towards the front.



Pivot the seat console (Fig. 28/1) open from the right-hand side of the vehicle, otherwise your hands could be crushed between the seat console and cab safety roof (if fitted).

4. Disconnect the battery and vehicle plug (Fig. 28/4+5).



When disassembling the batteries, use appropriate lifting gear.

Maintenance and Service



The battery may only be disassembled using lifting gear by properly trained personnel.



If the scrubber-drier is equipped with a cab safety roof, lift the batteries out on the left-hand side of the battery. The cab safety roof has a recess for the lifting gear rope.

5. Lift the batteries out of the vehicle using a lifting gear.



Guide the lifting gear from the left to the battery.

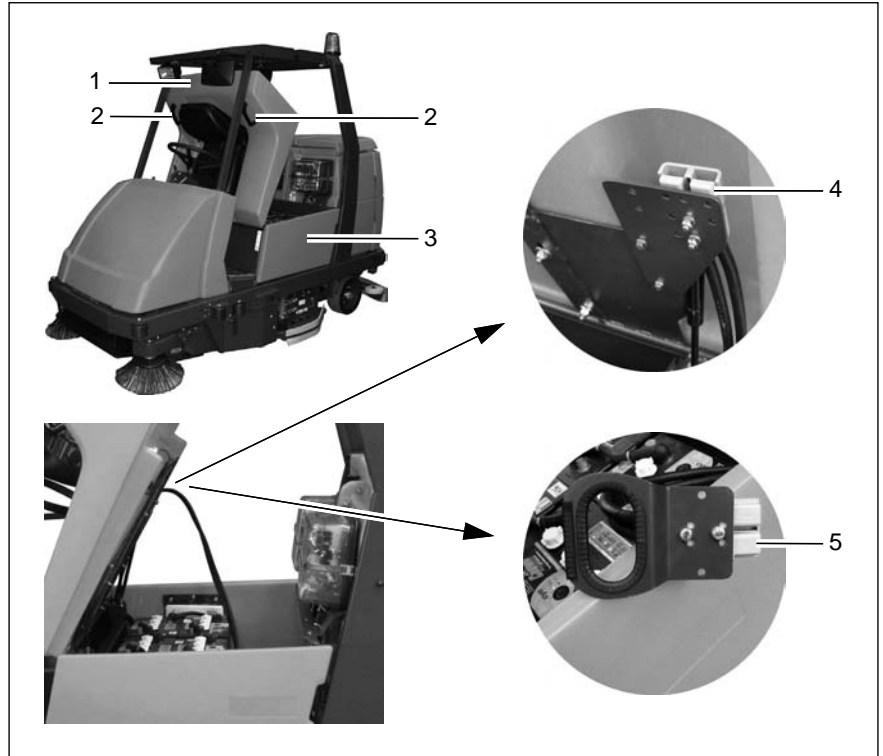

Fig. 28

Maintenance and Service

5.4.4 Installing the battery



Set the key switch to position 0 (refer to section "Key switch" in Section 3.2.3) and remove the key.

1. Open the side doors to the left and right (Fig. 28/3).
2. Take hold of the seat console (Fig. 28/1) at the handle (Fig. 28/2) and pivot it forwards to open it.



If a cab safety roof is fitted, open the seat console from the right-hand side of the vehicle, otherwise your hands could be crushed between the seat console and cab safety roof.

Install the 6 monobloc batteries into the tray in the vehicle from the left-hand side of the vehicle using lifting gear or a fork-lift truck according to Figure 28.



If the scrubber-drier is fitted with a cab safety roof, the battery can only be installed from the left-hand side of the vehicle; the cab safety roof is provided with a recess for the lifting gear rope.



When installing the battery, use appropriate lifting gear.



The battery may only be installed using lifting gear by properly trained personnel.

Connect the battery plug (Fig. 28/5) and vehicle socket (Fig. 28/4) to each other. Ensure they are connected firmly.

5.4.5 Disposing of batteries

Used batteries with the recycling symbol contain reusable commodities. The heavy metals contained represent a major risk both to people's health and to the environment. Never open or damage batteries. Never touch, inhale or swallow the content of batteries. Health hazard! Do not allow batteries to get into the environment. Risk of contaminating the ground and water! In accordance with symbol with the crossed out garbage bin, these batteries must not be disposed of in domestic waste. Return and recycling of old batteries must be agreed on with the authorized PowerBoss dealer in accordance with national requirements.

5.4.6 Deep discharge signal transducer (BMS)

The scrubber drier is equipped with a charge control for protection against deep discharge of the batteries. The deep discharge signal transducer (BMS) is integrated in the electronic system and setup at the factory for battery type GiS (digit in the service indicator: No. 5). If other batteries are used, the deep discharge signal transducer must be adjusted.



The deep discharge signal transducer may only be adjusted by an authorized PowerBoss service center.

Also refer to Section 3.1.9.

5.5 Fresh water tank

- 1 Lid seal
- 2 Lid
- 3 Opening to recovery tank
(airing and venting)
- 4 Fresh water tank
- 5 Fresh water filter
- 6 Ball cock
- 7 Lock
- 8 Fresh water draining hose

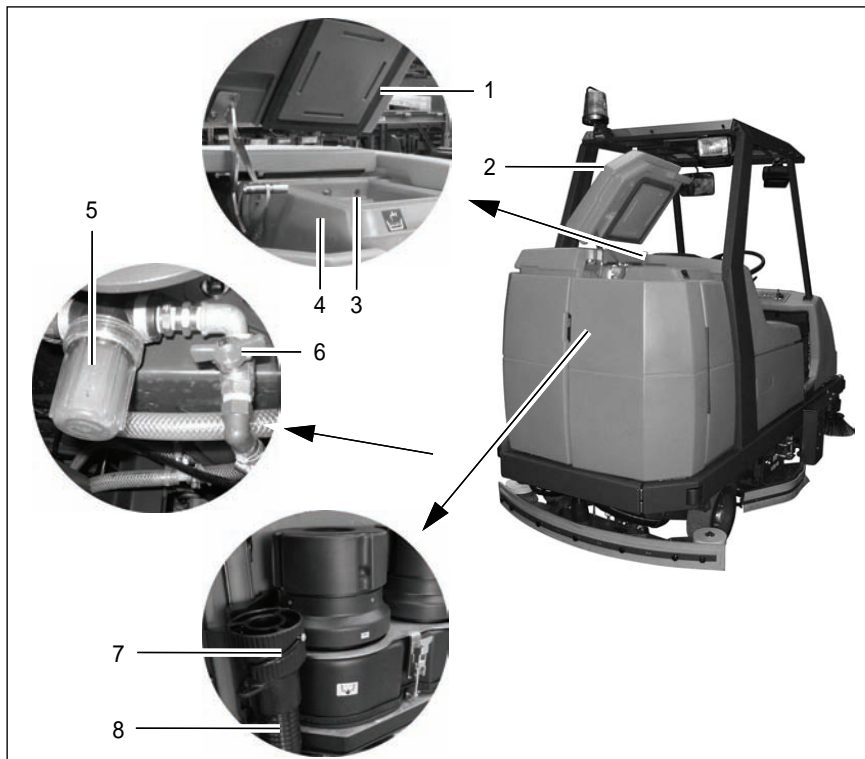

Fig. 29

Maintenance and Service

5.5.1 Filling the fresh water tank

Fill the fresh water tank (Fig. 29/4) with fresh water and cleaning agent before starting with the work, also refer to Section 3.1.5.

1. Park the machine on a level floor area.
2. Open the tank lid (Fig. 29/2) and lock in place.
3. Fill the fresh water tank to the maximum mark.



Only fill water at maximally 122 °F!

4. Mix cleaning agent in accordance with the manufacturer's instructions.
5. Close the lid (Fig. 29/2) on the fresh water tank.

Filling the fresh water tank via the automatic filling device



Please observe the guidelines provided by the water supply company. The vehicle must not be connected directly to a public drinking water supply to prevent chemicals getting into the drinking water supply. A brief connection is permitted, however, if a backflow preventer with pipe aerator is installed in the supply line. A backflow preventer of the type EA 3 or EA 2 must be installed.

1. Open the rear doors on the left and right as well as the rear panel frame (Fig. 23/7-9).
2. Connect a filling hose (Fig. 30/3) with a connection diameter of 0.7 in (3/4 inch).

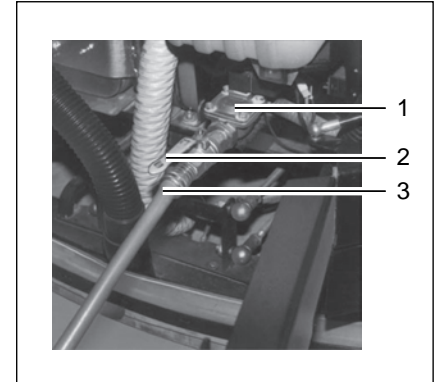

Fig. 30

3. Open the ball cock (Fig. 30/2).
4. Press the button for the solenoid valve (Fig. 30/1). This is located under the suction turbine.



The button for the solenoid valve (Fig. 30/1) can also be actuated when the key switch is switched off.

Maintenance and Service

5. Open the water tap on site.



Only fill water at maximally 122 °F!

On reaching the maximum fill level, the float switch in the fresh water tank closes the solenoid valve automatically.



Check the float switch regularly for soiling!

6. Close the water tap on site.
7. Close the ball cock (Fig. 30/2).
8. Disconnect the filling hose (Fig. 30/3).
9. Close the rear doors on the left and right as well as the rear panel frame (Fig. 23/7-9).
10. Close the lid (Fig. 29/2) on the fresh water tank.
11. Mix cleaning agent in accordance with the manufacturer's instructions.
12. Close the lid (Fig. 29/2) on the fresh water tank.

5.5.2 Emptying the fresh water tank

If the vehicle is to be left unused for a longer period, the fresh water tank (Fig. 29/4) should be emptied.

1. Park the vehicle so that the draining hose for fresh water (Fig. 29/8) can be positioned over a drain in the floor.
2. Open the left and right rear doors.
3. Open the rear panel frame.
4. Detach the fresh water draining hose (Fig. 29/8) and lower it slowly.
5. Unscrew the cap (Fig. 29/7) to open it. The quantity drained can be regulated by turning the screw cap and pivoting the cap open fully, if necessary.
6. When the fresh water tank has been completely emptied, screw the cap shut again and attach the draining hose again.
7. Close the rear panel frame.
8. Close the left and right rear doors.



When disposing of the waste water containing the cleaning agent, observe all applicable legal regulations.

5.5.3 Cleaning the draining hose cap

- The screw cap (Fig. 29/7) at the end of the draining hose (Fig. 29/8) should be cleaned at regular intervals.
- Lubricate the O-ring lightly, if necessary.

5.5.4 Cleaning the fresh water filter

The fresh water supply is equipped with a filter (Fig. 29/5) which must be cleaned if dirt appears on the container. This is located on the left-hand side of the vehicle at the height of the brushes behind the side panel.

1. Close the ball cock (Fig. 29/6) to prevent fresh water being supplied from the tank.
2. Unscrew the container by hand and pull the sieve insert out downwards.
3. Clean both parts with water and reassemble them.

5.6 Recovery tank

- 1 Lid
- 2 Lid seal
- 3 Recovery tank
- 4 Air intake filter
- 5 Lock
- 6 Waste water draining hose
- 7 Cleaning flap



Fig. 31

Maintenance and Service

5.6.1 Emptying the recovery tank



The recovery tank (Fig. 31/3) must be emptied and flushed clean after finishing work.



Observe the applicable laws and local regulations when disposing of waste water containing cleaning agents!

1. Park the vehicle so that the waste water draining hose (Fig. 31/6) can be positioned over a drain in the floor.
2. Open the left and right rear doors.
3. Open the rear panel frame.
4. Detach the waste water draining hose (Fig. 31/6) and lower it slowly.

5. Unscrew the cap (Fig. 31/5) to open it. The quantity drained can be regulated by turning the cap and pivoting the cap open fully, if necessary.
6. When the recovery tank has been completely emptied, screw the cap shut again and attach the draining hose again.



If the recovery tank is extremely dirty, begin cleaning the tank straight away.

7. Close the rear panel frame.
8. Close the left and right rear doors.

5.6.2 Cleaning the recovery tank

Clean the recovery tank (Fig. 31/3) every day or as necessary. The cleaning flap (Fig. 31/7) is available for this.

1. Open the left and right rear doors.
2. Open the rear panel frame.
3. Empty the recovery tank, refer to Section 5.6.1.

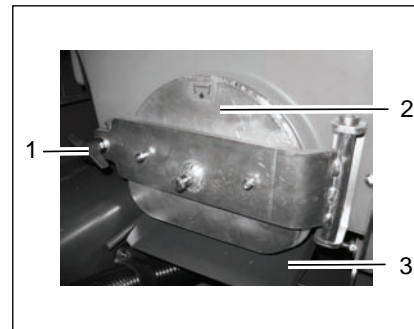

Fig. 32

4. Pull out the run-off plate (Fig. 32/3).
5. Release the flap lock: turn the wing nuts (Fig. 32/1) counterclockwise.
6. Open the cleaning flap (Fig. 32/2).

Maintenance and Service

7. Open the recovery tank lid (Fig. 31/1).
8. Flush the recovery tank with water filled from the top through the open tank lid.



Cleaning may only be carried out using a water hose (operating pressure approx. 72.51 to 87.01 psi) and only from top to bottom. Do not aim the jet of water directly at openings, slits, electronic components, operating panels or seals.



It is not permitted to clean the vehicle with a high-pressure washer or with a steam blaster because the temperature is in excess of 212 °F.



Wear appropriate gloves for protection against dirt, viruses, bacteria etc. when cleaning the container.

9. After finishing cleaning the tank, close the flap and push the run-off plate back in place.
10. Unhook the waste water draining hose (Fig. 31/6), lower it slowly and open the cap (Fig. 31/5).
11. Run fresh water in the recovery tank through the open lid using a water hose (output pressure approx. 72.51 to 87.01 psi) and, in doing so, also flushing the draining hose (see above).
12. Screw the cap shut again and hook the draining hose back in place.
13. Close the rear panel frame.
14. Close the left and right rear doors.



The cleaning flap must not be used to drain off waste water.

5.6.3 Cleaning the draining hose cap

- Clean the screw cap on the waste water draining hose (Fig. 31/6) daily.
- Lubricate the O-ring lightly, if necessary.

Maintenance and Service

5.6.4 Cleaning the air intake filter

The filter sieve (Fig. 33/1) is located in the recovery tank above the maximum water level on the suction pipe. The accumulation of dirt in the filter sieve must be checked daily and cleaned as necessary:

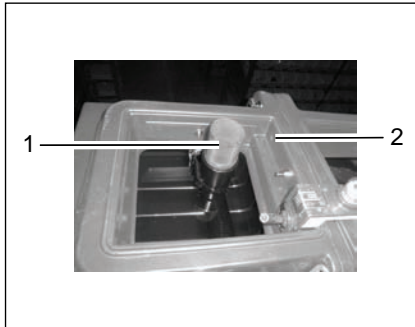

Fig. 33

1. Pull the filter sieve from the suction pipe and clean with water.



Remove the filter sieve completely to clean it.



During cleaning and operation, pay attention that no water and no particles of dirt get into the suction pipe and into the suction turbines.

2. Dry the filter sieve after cleaning. Do not replace when dripping wet!

5.6.5 Cleaning the openings to the fresh water tank

The openings between the recovery and fresh water tank (Fig. 33/2) serve for ventilation between the two tanks. They must be checked regularly for accumulations of dirt and cleaned as necessary.

Maintenance and Service

5.7 Scrubbing unit



The scrubbing unit (Fig. 34/1) may only be disassembled and assembled by properly trained service personnel.

The brushes, part of the scrubbing unit, are not contained in the scope of delivery. Select the brushes according to your needs and install them on the brush head (Fig. 34/2) according to the instructions, refer to Section 2.3.1.



Please refer to Chapter 4 or our spare parts catalogue on our internet site at www.powerboss.com for brushes etc.

5.7.1 Changing the brushes

- Check the brushes on the brush head weekly for signs of wear.
- When the brushes have worn to a bristle length of 0.6 in, the brushes must be replaced, refer to Section 2.3.1.



Before working on the brushes, switch off the scrubbing unit, turn the key switch to position 0 and remove the key.



Fig. 34

5.7.2 Installing new rubber deflector strips

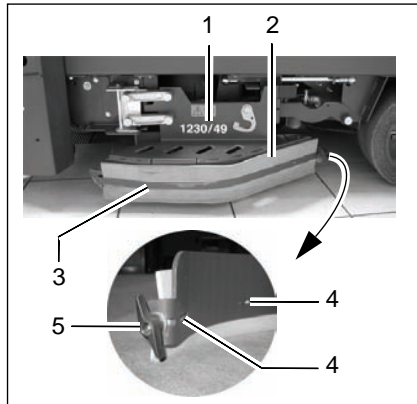

Fig. 35

- 1 Deflectors
- 2 Rubber deflector strips
- 3 Clamping rail
- 4 Clamping rail hooks
- 5 Wing nuts



The deflector (Fig. 35/1) must be fixed in its service position (refer to Section 2.3.1, Point 1).

1. Unscrew the wing nut (Fig. 35/5) at the end of the deflector.
2. Slide the clamping rail (Fig. 35/3) in the vehicle's driving direction (forwards) until the clamping rail hooks (Fig. 35/4) are freed and the clamping rail (Fig. 35/3) can be removed away from the vehicle.
3. Remove the old rubber deflector strips (Fig. 35/2).
4. Position the new rubber deflector strips (Fig. 35/2) in place.
5. Mount the clamping rail (Fig. 35/3) from the outside and slide back by hand so that the clamping rail hooks (Fig. 35/4) engage.

Screw the wing nut (Fig. 35/5) on the thread at the end of the clamping rail (Fig. 35/3), thus tightening the clamping rail (Fig. 35/3).

Maintenance and Service

5.8 Squeegee

- 1 Squeegee holding attachment
- 2 Wing nuts
- 3 Connection nozzle
- 4 Sealing strip (rear)
- 5 Support strip (rear)
- 6 Clamping rail (rear)
- 7 Support roller
- 8 Knurled nut

The squeegee is also equipped with front sealing and support strips and clamping rail (Fig. 37).

5.8.1 Cleaning the squeegee

Inspect the squeegee when raised daily and clean as necessary.

5.8.2 Disassembling the squeegee

1. Insert the key in the key switch and turn the key switch on.
2. Lower the squeegee: Press the button for the squeegee and suction turbine so that the green control lamp lights up.

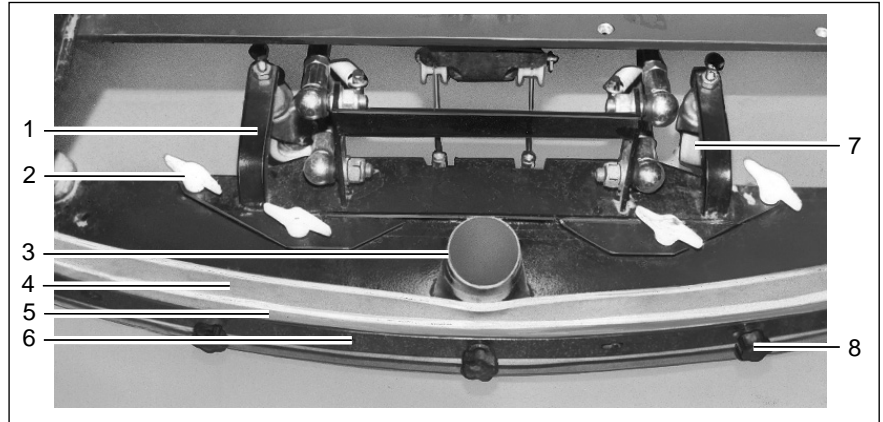

Fig. 36

3. Switch off the key switch and remove the key.
4. Open the rear doors.
5. Pull the suction hose from the connection nozzle (Fig. 36/3) of the squeegee.
6. Loosen the wing nuts (Fig. 36/2) on the holding attachment.

7. Pull the squeegee away to the rear under the holding attachment.
8. Insert the key in the key switch and turn the key switch on.
9. The squeegee is raised automatically.
10. Close the rear doors.

Maintenance and Service

5.8.3 Installing the squeegee

Refer to Section 2.3.2.

5.8.4 Changing the sealing strips

The sealing strips (Fig. 36/4) can be changed without the need for any tools:

1. Disassemble the squeegee, refer to Section 5.8.2
2. Unscrew the knurled nuts (Fig. 36/8).
3. Remove the sealing strip, support strip and clamping rail (Fig. 36/4-6).



Both sides of the sealing strip can be used.

4. Install the new or reversed sealing strips in the reverse working sequence.



Pay attention that both sealing strips (front and rear) touch the floor when mounted.

5. Tighten the knurled nuts (Fig. 36/8) evenly, starting from the center and working on alternate sides.



There must be no bends in the sealing strip.

6. Disassemble the front sealing strip (Fig. 37) in the same way.

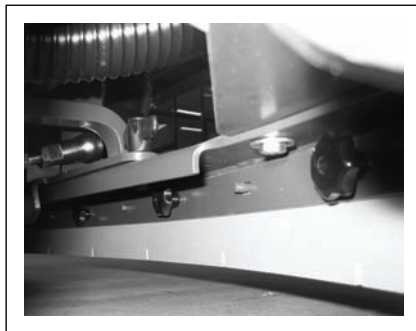

Fig. 37

7. After changing the sealing strips, check that the squeegee stands vertically on the floor. Otherwise, readjust the support rollers.



When the vehicle is in operation, the sealing strips must be bent a little to the rear when the squeegee is lowered.

5.8.5 Adjusting the support rollers

The squeegee stands with the sealing strips (Fig. 36/4) and support rollers (Fig. 36/7) on the ground. To increase the squeegee contact surface of the sealing strips (Fig. 36/4) on the floor, e.g. following wear of the sealing strips (Fig. 36/4), the support rollers (Fig. 36/7) must be set higher:

1. Position the squeegee on a level, solid surface.
2. Loosen the conternuts in each support roller.
3. Adjust the support rollers (Fig. 36/7) on the right and left evenly:
 - Turn the screw counterclockwise to raise the support roller.
 - Turn the screw clockwise to lower the support roller.
4. Check the squeegee contact surface and adjust, if necessary.
5. Tighten the conternuts on each support roller (Fig. 36/7).

5.9 Pre-sweep/Vacuum unit



Set the key switch to position 0 for all maintenance and repair work to prevent starting up the vehicle inadvertently!

5.9.1 Emptying the dirt hopper



The dirt hopper must be emptied and cleaned at least once a day. If the vehicle is used for several hours a day, the dirt hopper must be checked and correspondingly more frequently emptied.

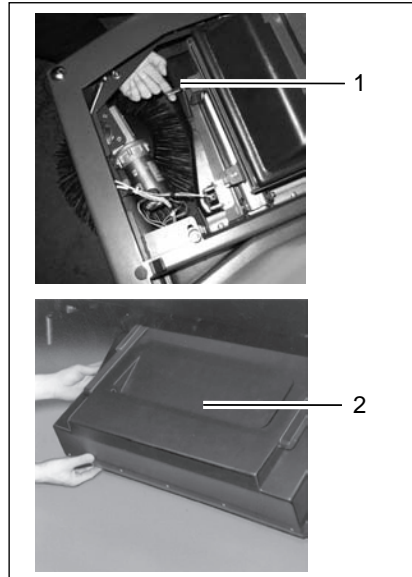

Fig. 38

- 1 Lock
- 2 Dirt hopper

(The top picture in Figure 38 illustrates the position of the left-hand lock when the front hood is open.)

Removing the dirt hopper



Only remove the hopper in the direct vicinity of the refuse dump/collection container.

1. When the front hood is closed, press the right and left locks (Fig. 38/1) of the dirt hopper (Fig. 38/2) up to release the lock. The dirt hopper pivots down.
2. Take hold of the dirt hopper (Fig. 38/2) in both hands using the grips located at the sides of the dirt hopper (Fig. 38/2).
3. Pull the dirt hopper (Fig. 38/2) to the front and out of the guide rails.

Maintenance and Service

Emptying the dirt hopper



Observe the applicable laws and local regulations in respect of disposal!

Empty the content of the dirt hopper (Fig. 38/2) in a waste container at regular intervals.

Installing the dirt hopper

1. Take hold of the dirt hopper (Fig. 38/2) in both hands using the grips located at the sides of the dirt hopper (Fig. 38/2).
2. Fit the dirt hopper (Fig. 38/2) in the guide rails, slide in as far as possible and press the dirt hopper (Fig. 38/2) upwards until the lock audibly latches into place.



If the dirt hopper (Fig. 38/2) is not properly engaged, the "Dirt hopper and front flap indicator of the pre-sweep/vacuum unit" lamp (Fig. 21/3) lights up. The pre-sweep/vacuum unit does not work.

5.9.2 Dust vacuum

The filter system of the dust vacuum (use category "U") is located in the filter case above the dirt hopper (Fig. 38/2). The filter case is movable, the movement linked to that of the dirt hopper (Fig. 38/2) in order to be able to shake the filter element (panel air filter) when the agitating motor is switched on.

Clearing the panel air filter of dust during operation

Clean the panel air filter (Fig. 39/2) in the dust vacuum regularly or as necessary using the agitating device:

- Press the "Button for agitating device" (Fig. 22/2). After pressing the button, an intermittent agitating process runs for approx. 6 seconds.
- To end the intermittent agitating process prematurely, press the same button (Fig. 22/2) again.
- Alternatively: Turn the key switch to position 0 or 1 (RESET).

Disassembling the panel air filter

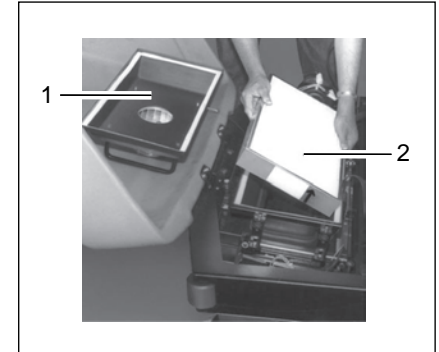

Fig. 39

- 1 Filter case cover with agitating motor
- 2 Filter element (panel air filter)

1. Open the front flap to the front.



The engine must have stopped before opening the front flap. Risk of injury!

2. Remove the straps holding the filter case cover (Fig. 39/1).
3. Remove the filter case cover (Fig. 39/1).

Maintenance and Service

4. Remove the panel air filter (Fig. 39/2).

Cleaning the panel air filter thoroughly



Do not inhale dusts. Health hazard! Always wear an appropriate dust mask.

Drop the panel air filter (Fig. 39/2) a few times, from a suitable height, onto a solid surface. Ensure the filter ribs are not damaged!



The surface must not have any irregularities. Do not let the panel air filter (Fig. 39/2) drop at a slant.



Do not install panel air filters (Fig. 39/2) which have damaged filter ribs!

Installing the panel air filter

The panel air filter (Fig. 39/2) must be installed in the reverse sequence to disassembly, refer to paragraph "Disassembling the panel air filter".



To not insert the panel air filter (Fig. 39/2) the wrong way round! Pay attention to the arrow on the frame of the panel air filter (Fig. 39/2)! The arrow must point upwards.

5.9.3 Side brushes

Side brush angle

The correct angle of the side brush is approx. 5-8° towards the front and side, it is setup at the factory and cannot be altered.

Adjusting the side brush contact

It may be necessary to readjust the side brush contact surface depending on the wear of the bristles:

1. Sit on the driver's seat, insert the key in the key switch and turn to position 1.
2. Press the "Button to switch the pre-sweep/vacuum unit on and off" (Fig. 22/4) to lower the side brush and cylindrical brush.
3. Turn the key switch to position 0 and remove the key. The cylindrical brush and side brush remain lowered.
4. Loosen the socket screw above the deflector plate.



The socket screw is locked by a hex nut.

Maintenance and Service

5. Slide the side brush including the deflector plate down slightly on the brush shaft.



The side brush contact surface is correct when approx. 1/3 of the side brush circumference makes contact with the ground.

6. Tighten the socket screw and lock it with the hex nut.

Disassembling the side brush

1. Refer to paragraph "Adjusting the side brush contact", Points 1-4
2. Pull the side brush including deflector plate downwards from the brush shaft.
3. Unscrew the three hexagon head bolts underneath the side brush and remove the side brush.

Installing the side brush

1. Refer to paragraph "Adjusting the side brush contact", Points 1-4
2. Screw on the (new) side brush to the deflector plate from below using three hexagon head bolts.
3. Slide the side brush including deflector plate from below on the brush shaft.
4. Adjust the side brush contact surface correctly, refer to paragraph "Adjusting the side brush contact".

5.9.4 Cylindrical brush

Checking the sweeping pattern

To prevent excessive bristle wear under normal working conditions, check the sweeping pattern regularly:

1. Park the vehicle on a level, smooth floor which is slightly dusty.
2. Sit on the driver's seat, insert the key in the key switch and turn to position 1.
3. Press the "Button to switch the pre-sweep/vacuum unit on and off" (Fig. 22/4) to start the side brushes and cylindrical brush rotating and to lower them.
4. Allow the pre-sweep/vacuum unit to operate for a short time while at a standstill.
5. Press the "Button to switch the pre-sweep/vacuum unit on and off" (Fig. 22/4) to stop the side brushes and cylindrical brush rotating and raise them.
6. Drive the vehicle forward a short way so that you can see the sweeping pattern (sweeping strokes).
7. Assess the sweeping pattern:

Maintenance and Service

Sweeping pattern is correct:

If the cylindrical brush is setup correctly, the swept area on the floor forms a rectangle whose side edges are parallel. The short sides of the rectangle should measure 1.2-2.0 in.



If the sweeping pattern is broader than 2.0 in, the brush pressure is too high. If the sweeping pattern is narrower than 1.2 in, the brush pressure is too low.



The shape of the sweeping pattern must be a rectangle and not trapeze or wedge shaped!

If the sweeping pattern is not correct, it must be adjusted; refer to paragraph "Setting the sweeping pattern".

Setting the sweeping pattern

The adjusting devices for the sweeping pattern can be accessed through the openings in the side collision protection on both sides of the vehicle.

1. Sit on the driver's seat, insert the key in the key switch and turn to position 1.

2. Press the "Button to switch the pre-sweep/vacuum unit on and off" (Fig. 22/4) to lower the side brush and cylindrical brush.
3. Turn the key switch to position 0 and remove the key. The cylindrical brush and side brush remain lowered.



All the adjustments must be made on both sides of the vehicle!

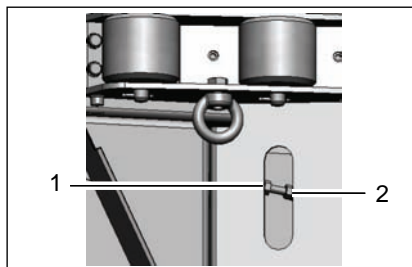

Fig. 40

- 1 Adjusting device for sweeping pattern
- 2 Counternut

4. Loosen the counternuts (Fig. 40/2) on both sides of the vehicle.
5. Turn the adjusting device (Fig. 40/1) on both sides of the vehicle as described below:
 - To make the sweeping pattern broader, turn counterclockwise.
 - To make the sweeping pattern narrower, turn clockwise.
6. Check the sweeping pattern, refer to paragraph "Checking the sweeping pattern".
7. Repeat steps 1 to 7 until the sweeping pattern is set correctly.
8. Tighten the counternuts (Fig. 40/2) on both sides of the vehicle.

Disassembling the cylindrical brush

The cylindrical brush can only be accessed from the right-hand side of the vehicle.

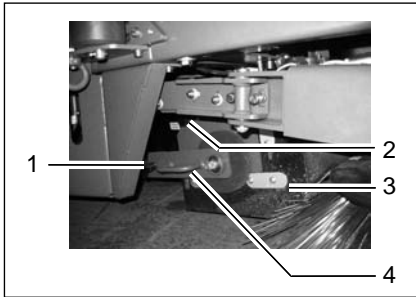

Fig. 41

- 1 Knurled screw for brush swing arm
- 2 Knurled screw for brush space cover
- 3 Brush space cover
- 4 Brush swing arm

1. Sit on the driver's seat, insert the key in the key switch and turn to position 1.
2. Press the "Button to switch the pre-sweep/vacuum unit on and off" (Fig. 22/4) to lower the side brush and cylindrical brush.
3. Turn the key switch to position 0 and remove the key. The cylindrical brush and side brush remain lowered.
4. Unscrew the knurled screw for the brush swing arm (Fig. 41/1).
5. Pull off the brush swing arm (Fig. 41/4).
6. Unscrew the knurled screw for the brush space cover (Fig. 41/2).
7. Remove the brush space cover (Fig. 41/3).
8. Pull the cylindrical brush out.

Installing the cylindrical brush

The cylindrical brush must be installed in the reverse sequence to disassembly, refer to paragraph "Disassembling the cylindrical brush".

Changing the belt for the cylindrical brush

The cylindrical brush is driven by a belt on the left-hand side.

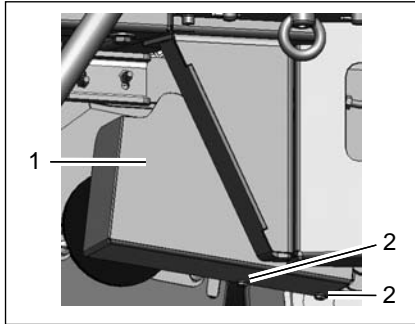

Fig. 42

The cover (Fig. 42/1) of the belt is fixed by two screws (Fig. 42/2).

1. Remove the screws (Fig. 42/2).
2. Remove the belt cover (Fig. 42/1).

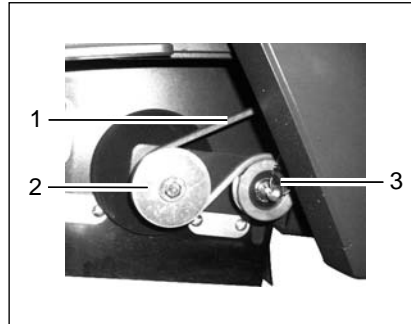

Fig. 43

3. Remove the belt (Fig. 43/1) from the pulleys (Fig. 43/2+3).
 4. Place a new belt in position.
 5. Assemble the belt cover (Fig. 42/1) and fix with the screws (Fig. 42/2).
- The belt tension is set by means of a spring mounted tension pulley (Fig. 43/3).

Maintenance and Service

5.10 Wheels

The wheel nuts on the wheels (Fig. 44/1) must be subjected to their first check after 100 operating hours and subsequently every 200 hours.



The tightening torque for the wheel nuts (Fig. 44/1) is 103.3 lb ft.

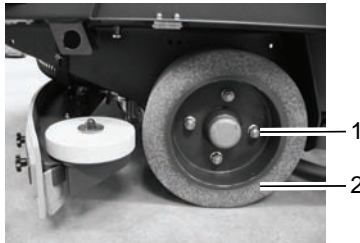

Fig. 44

5.10.1 Changing the rear wheels

1. Jack up the scrubber-drier on the left or right side: The contact points for the jack (lifting power: 2.0 t) are on the frame in front of the rear wheels.
2. Remove the wheel nuts (Fig. 44/1).
3. Pull off the wheel (Fig. 44/2).
4. Fit a wheel (Fig. 44/2).
5. Screw on and tighten the wheel nuts (Fig. 44/1).

5.10.2 Changing the front wheel

The procedure to change the front wheel is analog to changing the rear wheels:

1. Apply the jack at the front centered to the vehicle's front frame and jack up the scrubber-drier.
2. Unscrew the wheel nuts.
3. Remove the wheel.
4. Install the wheel in place.
5. Screw on and tighten the wheel nuts.

5.11 Electrical installation

5.11.1 Red control lamps

Refer to Section 3.2.2.

5.11.2 Error codes

Refer to Sections 3.5.1 and 3.2.2.

5.11.3 Fuses

The fuses are located in the electronic system underneath the seat console. Take hold of the seat console by the handle and pivot it up.



Always disconnect the battery plug before starting any work on the electrical installations.

All the stroke elements, all brush motors for the scrubber-drier and all motors for the side brushes and cylindrical brush of the pre-sweep/vacuum unit are equipped with safety fuses and electronic fuses.

Safety fuses are installed in:

- the main fuse (200A high current fuse (F50))
- the DC-DC converter (10A plug-in fuse (A8))



When these fuses blow, the vehicle is out of operation. This is not indicated by an alarm signal on the operating panel!

- the control unit (2A plug-in fuse (A1))



When these fuses blow, the vehicle is out of operation. This is not indicated by an alarm signal on the operating panel!

- the suction turbines (35A high current fuse)
- the water pump and relief valve for the water supply (10A plug-in fuse)
- the drive motor (160A current limiter in the drive control)
- the extractor fan of the pre-sweep/vacuum unit (20A plug-in fuse)
- the agitating motor for the pre-sweep/vacuum unit (20A plug-in fuse) and

- the working lights and flashing beacon, automatic filling device, key switch and horn (10A plug-in fuse (F51))



When these fuses blow, the vehicle is out of operation. This is not indicated by an alarm signal on the operating panel!

5.11.4 Drive control relay

The drive control is located in the left-hand part of the driver's cab underneath the foot plate.



Always disconnect the battery plug before starting any work on the electrical installations.

1. Loosen the screws in the foot plate and remove the foot plate.
2. Relay K3 (main contactor) is mounted upstream from the drive control.
3. Replace a defect relay with a new one.
4. Replace the foot plate and fix by means of the screws.

Maintenance and Service

5.12 Cleaning the vehicle

1. Clean the vehicle on a weekly basis, refer to Section 5.3.1.
2. Park the vehicle in an appropriate washing area.



Observe the applicable laws and local regulations when disposing of water containing cleaning agents and dirt!

3. Switch the vehicle off and remove the key.
4. The vehicle may only be cleaned using a water hose (operating pressure approx. 72.51 to 87.01 psi) and only from top to bottom.



It is not permitted to clean the vehicle with a pressure washer or steam blaster.

5. Do not aim the jet of water directly at openings, slits, electronic components, operating panels or seals.
6. It is not permitted to use aggressive and corrosive cleaning agents.
7. Allow the vehicle to dry after cleaning. It is preferable to allow the vehicle to dry over a longer period of time, e.g. the weekend.

5.13 Transport and towing

Loading



Observe the operating information on transportation!



Check the load bearing capacity of the loading platform prior to loading.

- Dead weight of the scrubber-drier without battery, without options and without driver: 2061 lbs
- Total weight of the scrubber-drier with battery and full fresh water tank, without driver: 3549 lbs
- When loading onto a truck or something similar by means of a loading ramp, the ramp angle must not exceed 15%.



The climbing capacities stipulated in this manual can and may only be achieved with the battery specified in the Section „Technical Data“.



Fig. 45

Maintenance and Service

- Squeegee, brush head and side brush and cylindrical brush of the pre-sweep/vacuum unit must be raised.

If the side brush collision protection option is assembled, it must be disassembled.

Transport

- When driving the vehicle (transport mode) to the site of use, the squeegee, scrubbing unit and side brushes and cylindrical brush on the pre-sweep/vacuum unit must be raised.
- When the vehicle is to be transported on another vehicle or trailer, it must be secured against rolling away. Lash the vehicle down securely. The vehicle is provided with attachment points (lashing eyes) on the left and right-hand side to do this: at the rear of the frame and on the sides at the height of the entry area (Fig. 45/1+2).

Towing the vehicle

If it should become necessary to tow the scrubber-drier, only do it on level ground and at a maximum towing speed of 2.5 mph. The tow rope must be attached at the front lashing points.

PowerBoss Made Simple Commercial Limited Warranty

Revision G

Effective September 2010

PowerBoss Made Simple Industrial Limited Warranty

Minuteman International owner of PowerBoss warrants to the original purchaser/user that the product is free from defects in workmanship and materials under normal use. PowerBoss will, at its option, repair or replace without charge, parts that fail under normal use and service when operated and maintained in accordance with the applicable operation and instruction manuals. All warranty claims must be submitted through and approved by factory authorized repair stations.

This warranty does not apply to normal wear, or to items whose life is dependent on their use and care. Parts not manufactured by PowerBoss are covered by and subject to the warranties and/or guarantees of their manufacturers. Please contact Minuteman International for procedures in warranty claims against these manufacturers.

Special warning to purchaser -- Use of replacement parts not manufactured by PowerBoss or its designated licensees, will void all warranties expressed or implied. A potential health hazard exists without original equipment replacement.

All warranted items become the sole property of Minuteman International or PowerBoss or its original manufacturer, whichever the case may be.

PowerBoss disclaims any implied warranty, including the warranty of merchantability and the warranty of fitness for a particular purpose. PowerBoss assumes no responsibility for any special, incidental or consequential damages.

This limited warranty is applicable only in the U.S.A. and Canada, and is extended only to the original user/purchaser of this product. Customers outside the U.S.A. and Canada should contact their local distributor for export warranty policies. PowerBoss is not responsible for costs or repairs performed by persons other than those specifically authorized by PowerBoss. This warranty does not apply to damage from transportation, alterations by unauthorized persons, misuse or abuse of the equipment, use of non-compatible chemicals, or damage to property, or loss of income due to malfunctions of the product. If a difficulty develops with this machine, you should contact the dealer from whom it was purchased.

This warranty gives you specific legal rights, and you may have other rights, which vary from state to state. Some states do not allow the exclusion or limitation of special, incidental or consequential damages, or limitations on how long an implied warranty lasts, so the above exclusions and limitations may not apply to you.

PowerBoss Made Simple Commercial Limited Warranty

	Travel*	Labor	Parts	Engine	Extended Warranty	Costs
Walk behinds						
Battery sweepers	Ninety days	One year	One year	N/A	2 years Parts + Labor (or 2000 Hours)	2%
IC sweepers	Ninety days	One year	One year	Through manufacturer	2 years Parts + Labor (or 2000 Hours)	2%
Battery scrubbers	Ninety days	Two years	Three years	N/A	3 Years Parts + Labor (or 3000 Hours)	2%
Riders						
Battery scrubbers	Ninety days	Two years	Three years/2000 hrs	N/A	3 Years Parts + Labor (or 3000 Hours)	2%
IC sweeper/scrubbers	Ninety days	Six months	Two years/2000 hrs	Two years/3000 hrs**	2 years Parts + Labor (or 2000 Hours)	3%
IC sweepers	Ninety days	Six months	Four years/3000 hrs	Five years/3000 hrs**	4 Years Parts + 2 Years Labor (or 4000 Hours)	3%
Exceptions						
Apex series sweeper	Ninety days	One year	One year/1000 hrs	One year/1000 hrs**	2 years Parts + Labor (or 2000 Hours)	3%
6X sweeper	Ninety days	Six months	Two years/2000 hrs	Two years/2000 hours**	2 years Parts + Labor (or 2000 Hours)	3%
Other Products						
QRE-3001A	Ninety days	Six months	Two years/2000 hrs	Two years/3000 hours**	2 years Parts + Labor (or 2000 Hours)	3%

Tank Bladders

Eight years/ no additional labor

Polyethylene plastic tanks

Ten years/ no additional labor

Batteries

0-3 months full replacement, 4-12 prorated credit

Chargers

One-year replacement

Replacement parts

Ninety days

***Two-hour cap**

****Through engine manufacturer. See section 3 of warranty manual for engine warranty exceptions**

***** Based upon dealer's certification status**

Extended Warranty MUST be signed up within 30 days of delivery to End User (Dealer has 1Year from Receiving Machine to Sign up extended Warranty)

Extended Warranty Cost is based on Invoice Price multiplied by the Percentage listed in the Extended Warranty Column

All above labor and travel reimbursed at 65 or 75% of the published shop rate.

Notes

Notes

PowerBoss®

Excellence Meets Clean

88-10-2987 Rev * 07/13



PowerBoss Inc. • 175 Anderson Street • Aberdeen, NC 28315 U.S.A.
Telephone: (910) 944-2105 • Fax: (910) 944-7409